

General Service Bulletin

Outdoor Fan Motor Bearing Failure Split Systems and Impact™ Units

ATTENTION: Warnings, Cautions and Notices appear at appropriate sections throughout this literature. Read these carefully:

⚠ WARNING Indicates a potentially hazardous situation which, if not avoided, could result in death or serious injury.

⚠ CAUTION Indicates a potentially hazardous situation which, if not avoided, could result in minor or moderate injury. It could also be used to alert against unsafe practices.

NOTICE: Indicates a situation that could result in equipment or property-damage only accidents.

⚠ SAFETY WARNING

Only qualified personnel should install and service the equipment. The installation, starting up, and servicing of heating, ventilating, and air-conditioning equipment can be hazardous and requires specific knowledge and training. Improperly installed, adjusted or altered equipment by an unqualified person could result in death or serious injury. When working on the equipment, observe all precautions in the literature and on the tags, stickers, and labels that are attached to the equipment.

⚠ WARNING

Personal Protective Equipment (PPE) Required!

Installing/servicing this unit could result in exposure to electrical, mechanical and chemical hazards.

- Before installing/servicing this unit, technicians **MUST** put on all Personal Protective Equipment (PPE) recommended for the work being undertaken. **ALWAYS** refer to appropriate MSDS sheets and OSHA guidelines for proper PPE.
- When working with or around hazardous chemicals, **ALWAYS** refer to the appropriate MSDS sheets and OSHA guidelines for information on allowable personal exposure levels, proper respiratory protection and handling recommendations.
- If there is a risk of arc or flash, technicians **MUST** put on all Personal Protective Equipment (PPE) in accordance with NFPA 70E or other country-specific requirements for arc flash protection, **PRIOR** to servicing the unit.

Failure to follow recommendations could result in death or serious injury.

Introduction

The purpose of this bulletin is to advise customers of a potential issue associated with outdoor fan motor bearings on certain Split Systems and Impack™ units, and to describe the corrective action.

Units potentially affected by this bulletin have a serial number range of 11111****L to 11282****L, 11113****H to 11284****H, and 11124****F to 11285****F.

The action described in this bulletin is not being taken to address a safety concern.

Discussion

These suspect units may be at risk of premature failure due to an improper wick placement in the outdoor fan motor.

An improperly placed wick will not lubricate the motor bearings correctly and may cause a premature motor failure.

Affected Motors

To determine whether a unit has a motor affected by this bulletin, do the following:

- Locate the data sticker on the outdoor fan motor.
- Locate the date code at the bottom of the sticker (see example below).
- There are four date codes that apply to this Service Bulletin: C11V, D11V, E11V, and F11V. Any unit with one of these date codes is recommended for motor replacement.
- Any unit that does not contain these date codes on the motor is not suspect and requires no action.



Parts Ordering Information

Obtain the required parts from your local Trane Parts Center:

Model Number	Part Number	Model Number	Part Number	Model Number	Part Number
4DCZ6036A1075B	MOT13827	4TWB3036A1000B	MOT13209	4YCC3048A4075A	MOT12403
4DCZ6048A1096B	MOT13827	4TWB3042A1000B	MOT13209	4YCC3048A4120A	MOT12403
4TCC3048A4000A	MOT12403	4TWB3048A1000B	MOT13209	4YCC3060A4096A	MOT12403
4TCC3060A4000A	MOT12403	4TWB3060A1000B	MOT13209	4YCC3060A4120A	MOT12403
4TTA3042A4000B	MOT12268	4WCC3030A1000A	MOT12919	4YCY4030A1075A	MOT12919
4TTA3048A3000B	MOT13209	4WCC3048A4000A	MOT12403	4YCZ6036A1075B	MOT13827
4TTA3048A4000B	MOT12268	4WCC3060A1000A	MOT12401	4YCZ6036A3075B	MOT13827
4TTA3060A3000B	MOT13209	4WCC3060A4000A	MOT12403	4YCZ6036A3096B	MOT13827
4TTA3060A4000B	MOT12268	4WCY4030A1000A	MOT12919	4YCZ6036A4075B	MOT13828
4TWA3036A3000B	MOT12535	4WCZ6036A1000B	MOT13827	4YCZ6036A4075C	MOT13828
4TWA3036A4000B	MOT12268	4WCZ6036A3000B	MOT13827	4YCZ6036A4096B	MOT13828
4TWA3042A3000B	MOT12535	4WCZ6036A4000B	MOT13828	4YCC3048A1096B	MOT13827
4TWA3042A4000B	MOT12268	4WCZ6048A1000B	MOT13827	4YCC3048A3096B	MOT13827
4TWA3048A3000B	MOT13209	4WCZ6048A3000B	MOT13827	4YCC3048A4096B	MOT13828
4TWA3048A4000B	MOT12268	4WCZ6048A4000B	MOT13828	4YCC3060A1075A	MOT12919
4TWA3060A3000B	MOT13209	4YCC3030A1075A	MOT12919	4YCC3030B1075A	MOT12919
4TWA3060A4000B	MOT12268				

Split Systems Outdoor Motor Replacement

⚠ WARNING

Hazardous Voltage!

Disconnect all electric power, including remote disconnects before servicing. Follow proper lockout/tagout procedures to ensure the power can not be inadvertently energized. Failure to disconnect power before servicing could result in death or serious injury.

Disassembly Procedure

1. Remove Control Panel from unit.
2. Remove 5/16" screws from the top assembly and save.



3. Disconnect motor leads in the control box.
4. Remove top assembly, and place it on a working platform that will not scratch the unit.
5. Note the position of the fan blade on the motor shaft and remove the blade.
6. Remove 1/4" screws attaching motor to grill and save.

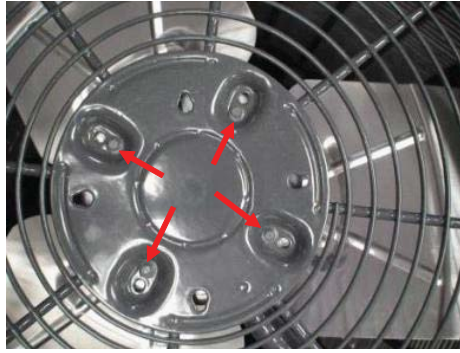

7. Separate motor from top assembly.
8. Pull the conduit through the fan orifice hole, remove the motor, and slide the conduit off the wires.

Assembly Procedure

1. Using a stiff wire with a hook on one end, pull the new motor wires through the conduit.
2. Install the new motor to the grill using the four 1/4" screws, and place the conduit back through the fan orifice hole.

Note: Torque to 65-80 in/lbs

3. Secure the fan blade to the shaft. The end of the fan hub must be flushed with the end of the shaft, and the bolt must be centered on the flat side of the shaft.

Note: Torque to 120-140 in/lbs



4. Install top assembly to unit using 5/16" screws, and route the conduit through the slot in the control box.

Important: Make sure that all wires are routed through the slot so they do not get pinched between the control box and the top assembly.

5. Check fan blades for even clearance.
6. Wire new motor leads in the control box:
 - a. On units with a single dual run capacitor:
 - i. The brown wire goes to the capacitor terminal marked "F"
 - ii. The purple wire goes to the capacitor terminal marked "C"
 - iii. The black wire goes to the top right side of the contactor (along with the other black wires).

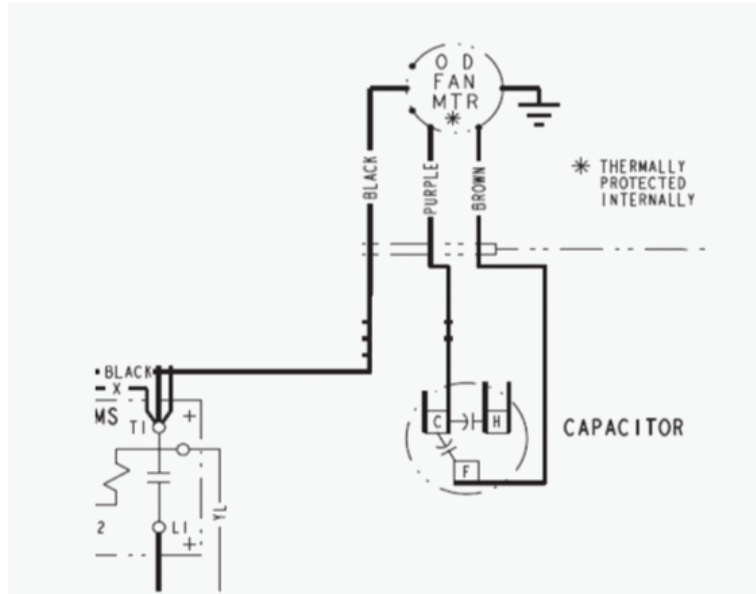

- b. On units with two individual capacitors:
- i. The brown wire goes to the small capacitor without the red wire.
 - ii. The purple wire goes to the small capacitor with the red wire.
 - iii. The black wire goes to the top left side of the contactor (along with the other black wires).

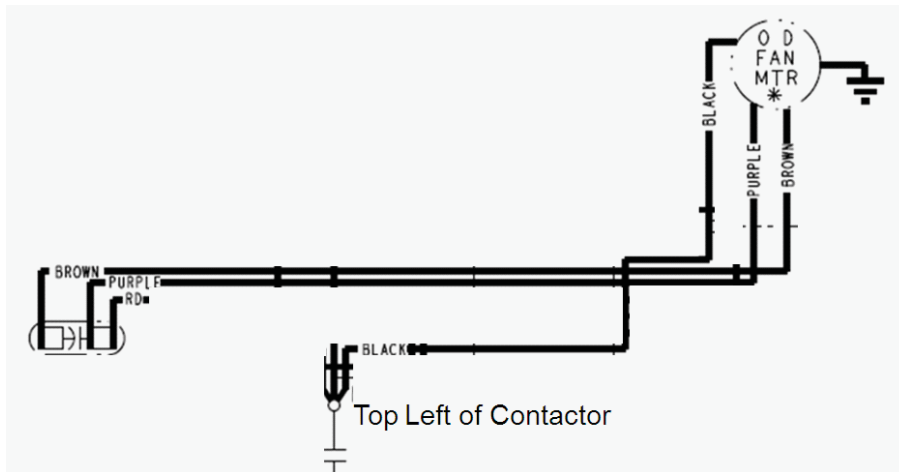

7. Install control box panel.

Impack™ Units Outdoor Motor Replacement

⚠ WARNING

Hazardous Voltage!

Disconnect all electric power, including remote disconnects before servicing. Follow proper lockout/tagout procedures to ensure the power can not be inadvertently energized. Failure to disconnect power before servicing could result in death or serious injury.

1. Remove compressor access panel from cabinet.
2. Disconnect the three motor leads found within compressor compartment.

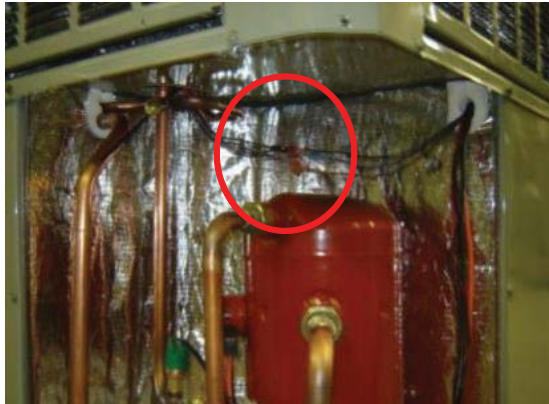

3. Remove screws attaching grill assembly to top cover, and lift fan grill assembly.
4. Remove fan blade from motor shaft.

Important: Note the position and height of the blade as it must be positioned the same on the new motor.

5. Cut cable tie securing motor leads to intermediate top cover.



6. Lay motor assembly on work surface with shaft down.
7. If model has a plastic cover on fan grill, remove it by prying upward with screwdriver.

NOTICE:

Cover Damage!

The notch in plastic cover must be aligned with conduit when reassembling. Failure to do so could result in damage to the cover.

8. Remove four 1/4" screws attaching grill to motor end bell.

9. Pull motor away from grill.
10. Remove conduit from motor housing connector.
11. Using a stiff wire with a hook on one end, pull the new motor wires through the conduit.
12. Install new motor and reverse prior steps to reassemble.

Parts Ordering Information

Obtain the required parts from your local Trane Parts Center.

Parts Disposal Information

Motors on systems that have already been installed in the field should be scrapped.

Questions

If you have questions and are a Trane distributor or a Commercial Sales Office, contact Light Commercial Technical Service in Clarksville. If you are not a Trane distributor or a Commercial Sales Office, contact the local Trane distributor or a Commercial Sales Office.

The manufacturer optimizes the performance of homes and buildings around the world. A business of Ingersoll Rand, the leader in creating and sustaining safe, comfortable and energy efficient environments, the manufacturer offers a broad portfolio of advanced controls and HVAC systems, comprehensive building services, and parts. For more information, visit www.IRCO.com.

The manufacturer has a policy of continuous product and product data improvement and reserves the right to change design and specifications without notice.