

VisionPRO™ 8000 Touchscreen Programmable Thermostat

PRODUCT DATA



FEATURES

- Large, clear display with backlight shows the current and set temperature and time—even in the dark.
- Menu-driven programming make setup effortless.
- Beautiful ergonomic design is smart and sophisticated to match your customers' lifestyle.
- Touchscreen interaction
- Real-time clock keeps time during power failures and automatically updates to daylight savings.
- "Saving Changes" notification lets you know when the schedule changes have been saved.
- Change/check reminders let you know when to service or replace filters or batteries.
- Various Hold options allow you to override the program schedule, as desired.
- Speedy same-schedule programming—no need to copy multiple days.
- Armchair programming allows you to remove the thermostat from the wall for programming.
- Programmable fan offers increased air quality when combined with a Honeywell whole-house air cleaner.

APPLICATION

The VisionPRO 8000 Touchscreen Programmable Thermostat is an effortless, 7-Day programmable thermostat that provides universal system compatibility, precise comfort control and is easy-to-program.

The TH8110 Thermostats provide temperature control for gas, oil, electric and heat pumps for 1 heat, 1 cool systems.

The TH8320 Thermostats provide temperature control for gas, oil, electric and heat pumps for up to 3 heat, 2 cool systems including dual fuel operation.

The TH8321 Thermostats provide temperature control for gas, oil, electric and heat pumps for up to 3 heat, 2 cool systems including dual fuel operation plus dehumidification control.

Contents

Application/Features	1
Specifications/Ordering Information	2
Installation	4
Wiring	5
Power the Thermostat	11
Installer Setup	15
Installer System Test	20
Operation.....	21
Programming.....	23
Troubleshooting.....	38



SPECIFICATIONS

Thermostat Description:

Feature	Description
Powering methods	<ul style="list-style-type: none"> Battery only Common wire only Common wire with battery backup
System types (up to 3 heat/2 cool or up to 1heat/1cool, depending on model)	<ul style="list-style-type: none"> Gas, oil or electric heat with air conditioning Warm air, hot water, high-efficiency furnaces, heat pumps, steam and gravity Heat only—includes power to open and power to close zone valves (series 20) and normally-open zone valves Heat only with fan Cool only 750 mV heating systems
Changeover	Manual or Auto changeover selectable
System setting	Heat-Off-Cool-Auto (Em. Heat for heat pumps)
Fan setting	Auto-On-Circ

Electrical Ratings:

Terminal	Voltage (50/60 Hz)	Running Current
W Heating	20 - 30 Vac	.02 - 1.0A
W Heating (Powerpile)	750 mV dc	100 mA dc
Y Cooling	20 - 30 Vac	.02 - 1.0A
G Fan	20 - 30 Vac	.02 - .60A

Temperature Setting Range:

Heating: 40°F to 90°F (4.5°C to 32°C).

Cooling: 50°F to 99°F (10°C to 37°C).

Operating Ambient Temperature:

TH8000 VisionPRO™ Thermostats: 0°F to 120°F (-18°C to 49°C).

C7089U: -40°F to 120°F (-40°C to 49°C).

C7189U: 45°F to 88°F (7.2°C to 32°C).

Shipping Temperature:

TH8000 VisionPRO™ Thermostats: -30 °F to 150 °F (-34.4°C to 65.6°C).

Operating Relative Humidity (Non-condensing):

TH8000 VisionPRO Thermostats: 5% to 90%.

C7089U: 5% to 95%.

C7189U: 5% to 95%.

Humidity Setting Range (TH8321 models only):

Cooling: 40% to 80% RH.

Humidity Display Range (TH8321 models only):

0% to 99%.

Cycle Rates (at 50% Load):

Heating: Selectable 1 - 12 cycles per hour.

Cooling: Selectable 1 - 6 cycles per hour.

Finish:

TH8000 VisionPRO™ Thermostats: Premier White® color.

C7189U Wall Mount Remote Indoor Sensor: Premier White® color.

Clock Accuracy: +/- 1 minute per month.

Batteries:

Three replaceable AAA alkaline batteries: Power thermostats when 24 Vac common is not used. Non-replaceable lithium battery with ten-year life under normal use to hold calendar and time settings. Alkaline batteries keep calendar and time after lithium battery is no longer functional.

Resistance Characteristics of Remote Sensors:

C7089U Outdoor Sensor: Negative temperature coefficient (NTC) means that resistance decreases as the temperature increases. See Table 13 in the Operation section for sensor resistance characteristics.

C7189U Remote Indoor Sensor: Negative temperature coefficient (NTC), means that resistance decreases as the temperature increases. See Table 14 in the Operation section for sensor resistance characteristics.

Cool Indication:

TH8000 VisionPRO™ Touchscreen Thermostats show "Cool On" on the screen when Cool is activated.

Heat Indication:

TH8000 VisionPRO™ Touchscreen Thermostats show "Heat On" on the screen when Heat is activated.

ORDERING INFORMATION

When purchasing replacement and modernization products from your TRADELINE® wholesaler or distributor, refer to the TRADELINE® Catalog or price sheets for complete ordering number.

If you have additional questions, need further information, or would like to comment on our products or services, please write or phone:

- Your local Honeywell Automation and Control Products Sales Office (check white pages of your phone directory).
- Honeywell Customer Care
1885 Douglas Drive North
Minneapolis, Minnesota 55422-4386

In Canada—Honeywell Limited/Honeywell Limitée, 35 Dynamic Drive, Scarborough, Ontario M1V 4Z9.

International Sales and Service Offices in all principal cities of the world. Manufacturing in Australia, Canada, Finland, France, Germany, Japan, Mexico, Netherlands, Spain, Taiwan, United Kingdom, U.S.A.

Auxiliary Heat Indication:

TH8000 VisionPRO™ Touchscreen Thermostats show “Aux. Heat On” on the screen when Auxiliary Heat is activated.

Emergency Heat Indication:

TH8000 VisionPRO™ Touchscreen Thermostats show “Heat On” on the screen when Emergency Heat is activated and the System mode is in the Em. Heat position.

Calibration:

C7089U, C7189U and TH8000 VisionPRO™ Touchscreen Thermostats are factory-calibrated and require no field calibration.

Interstage Differential:

TH8000 VisionPRO™ Touchscreen Thermostats operate with droopless control. Once the thermostat senses that 1st stage is running at 90% capacity, the thermostat energizes 2nd stage.

Nomenclature:

Series	System Stages	Application	Power and System Changeover
VisionPRO™ 8000 Touchscreen	11 - 1H/1C 32 - 3H/2C	0 - Standard 1 - Humidity Sensor	U - Universal (Auto changeover and/or manual change-over) dual powered, system flexibility, schedule flexibility.

Mounting Means:

TH8000 VisionPRO™ Touchscreen Thermostat: Mounts directly on the wall in the living space using mounting screws and anchors provided. Fits a vertical or horizontal 2 x 4 in. junction box.

C7089U Outdoor Sensor: Mounts outside of living space with mounting clip and screws provided.

C7189U Remote Indoor Sensor: Mounts directly on the wall using mounting screws and anchors provided. Fits a vertical 2 x 4 in. junction box.

Cover Plate:

32003796-001 Cover Plate is used to cover marks left on the wall by the old thermostat.

Dimensions:

TH8000 Touchscreen Thermostat: see Fig. 1.

C7089U Outdoor Sensor Mounting Clip: see Fig. 2.

32003796-001 Cover Plate: see Fig. 3.

C7189U Remote Indoor Sensor: see Fig. 4.

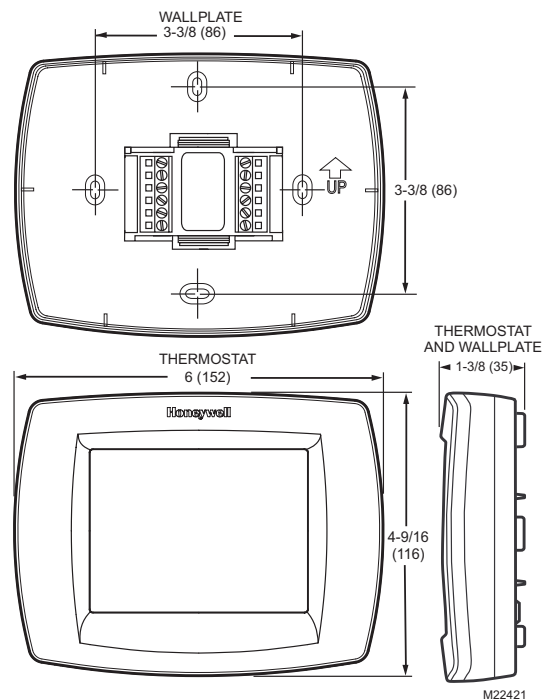

Fig. 1. TH8000 Touchscreen Thermostat dimensions in in. (mm).

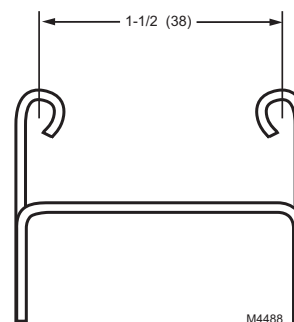

Fig. 2. C7089U Outdoor Sensor Mounting Clip dimensions in in. (mm).

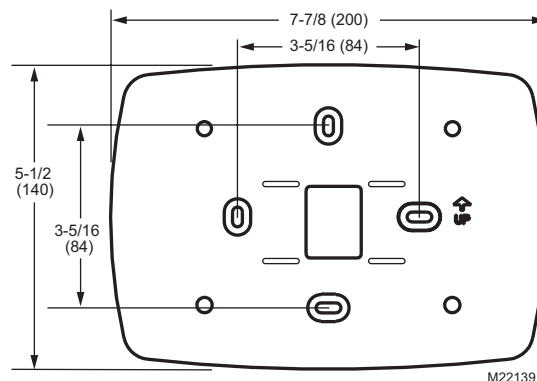

Fig. 3. 32003796-001 Cover Plate dimensions in in. (mm).

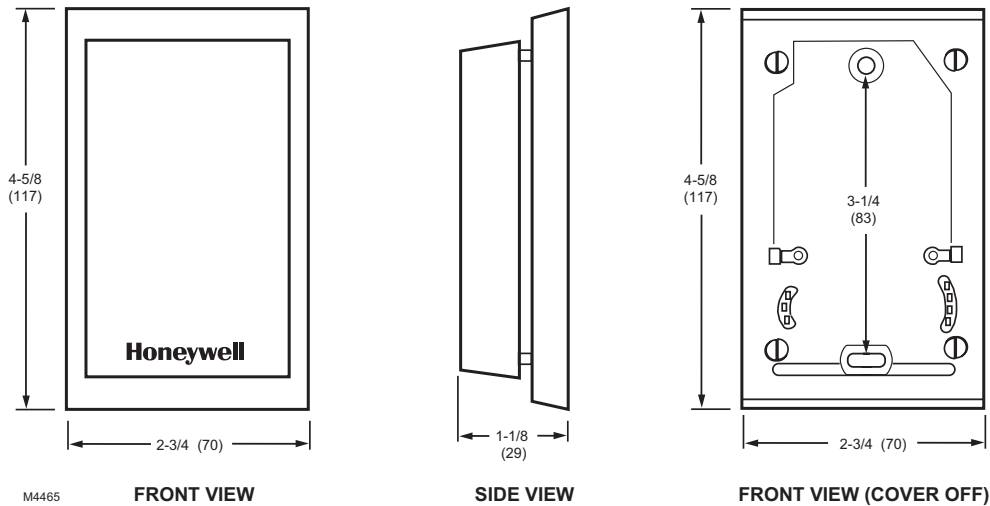

Fig. 4. C7189U Remote Indoor Sensor dimensions in in. (mm).

INSTALLATION

When Installing this Product...

1. Read these instructions carefully. Failure to follow the instructions can damage the product or cause a hazardous condition.
2. Check the ratings given in the instructions to make sure the product is suitable for your application.
3. Installer must be a trained, experienced service technician.
4. After completing installation, use these instructions to check out the product operation.

Selecting Location

Install the thermostat about 5 ft. (1.5m) above the floor in an area with good air circulation at average temperature. See Fig. 5.

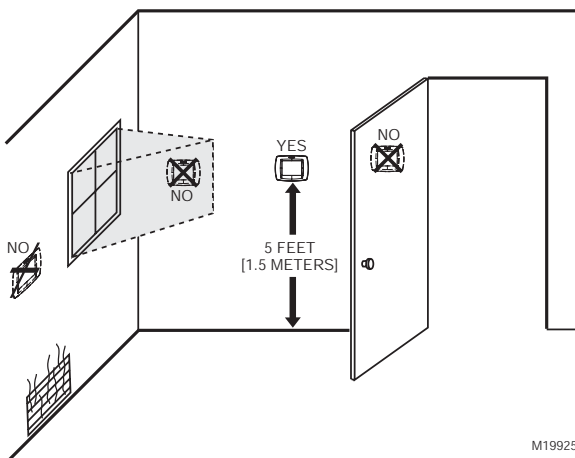

Fig. 5. Selecting thermostat location.

Do not install the thermostat where it can be affected by:

- Drafts or dead spots behind doors and in corners.
- Hot or cold air from ducts.
- Radiant heat from sun or appliances.
- Concealed pipes and chimneys.
- Unheated (uncooled) areas such as an outside wall behind the thermostat.

Installing Wallplate



CAUTION

Electrical Hazard.

Can cause electrical shock or equipment damage.

Disconnect power before wiring.

The thermostat can be mounted horizontally on the wall or on a 4 in. x 2 in. (101.6 mm x 50.8 mm) wiring box.

1. Position and level the wallplate (for appearance only).
2. Use a pencil to mark the mounting holes.
3. Remove the wallplate from the wall and, if drywall, drill two 3/16-in. holes in the wall, as marked. For firmer material such as plaster, drill two 7/32-in. holes. Gently tap anchors (provided) into the drilled holes until flush with the wall.

4. Position the wallplate over the holes, pulling wires through the wiring opening. See Fig. 6.
5. Insert the mounting screws into the holes and tighten.

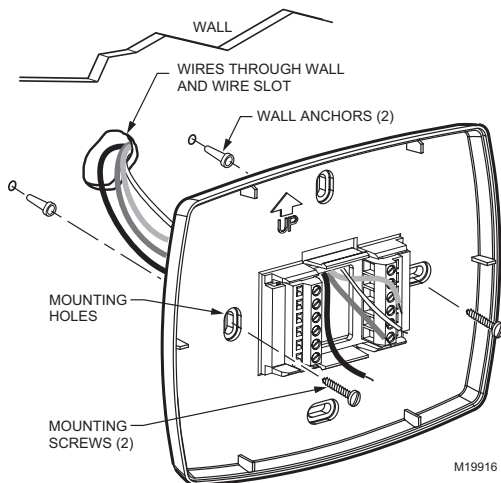

Fig. 6. Mounting wallplate.

WIRING (FIG. 9 - 21)

All wiring must comply with local electrical codes and ordinances.

1. Select set of terminal identifications (Table 1) that corresponds with system type (conventional or heat pump in Fig. 7).
2. Loosen the screws for the appropriate system type selected; see Table 1. See Table 2 for terminal designation descriptions. Insert wires in the terminal block under the loosened screw. See Fig. 8.
3. Securely tighten each screw.
4. Push excess wire back into the hole.
5. Plug the hole with nonflammable insulation to prevent drafts from affecting the thermostat.
6. See Fig. 9 through 21 for typical wiring hookups.

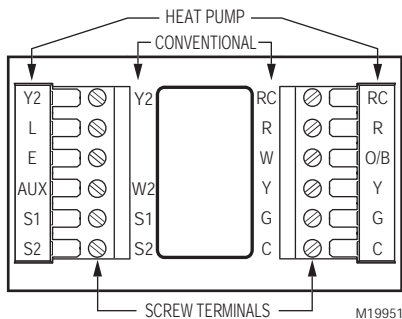

Fig. 7. Selecting terminal identifications for system type.

Table 1. Selecting Terminal Identifications for System Type.

System Type	Wallplate Terminal Identifications	Wiring Diagram Reference
Standard Heat/Cool	Conventional	9, 10
Heat Only	Conventional	11
Heat Only with Fan	Conventional	12
Heat Only (Series 20) Power to open and power to close zone valves	Conventional	13
Normally Open Zone Valves—Heat Only	Conventional	14
Cool Only	Conventional	15
Standard Multistage up to 2 Heat/2 Cool	Conventional	16, 17
Heat Pump with No Auxiliary Heat	Heat Pump	18, 19
Heat Pump with Auxiliary Heat	Heat Pump	20, 21

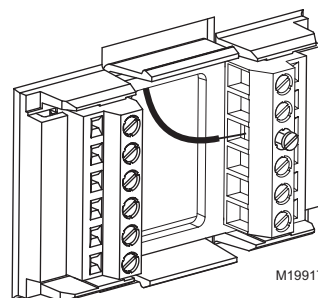

Fig. 8. Inserting wires in terminal block.

IMPORTANT

Use 18 gauge thermostat wire.

Table 2. Terminal Designation Descriptions.

Terminal Designation	Description
Rc (see Note 1)	Power for cooling--connect to secondary side of cooling system transformer
R (see Note 1)	Power for heating--connect to secondary side of heating system transformer
C (see Note 2)	Common wire from secondary side of cooling system transformer
W	Heat relay
Y	Compressor contactor
G	Fan relay
Y2	Second stage cooling
W2	Second stage heat relay
O/B (see Note 3)	Changeover valve for heat pump systems
AUX	Auxiliary heat relay for heat pump systems
E	Emergency heat relay for heat pump systems
L (see note 4)	Equipment monitor for heat pump systems
S1, S2	Optional outdoor or indoor remote sensor

NOTES:

- When used in a single-transformer system, leave metal jumper wire in place between Rc and R. If used on a two-transformer system, remove metal jumper wire between Rc and R.
- Common wire is optional when thermostat is used with batteries.
- If thermostat is configured for a heat pump system in the Installer Setup, configure changeover valve for cool (O-factory setting) or heat (B).
- L terminal is an input (system monitor) when the System mode is in the Heat, Off, Cool or Auto position. L terminal is a 24 Vac output when System mode is Emergency Heat. Must connect the 24 Vac Common when using the L terminal. See LED Indication section for more details.

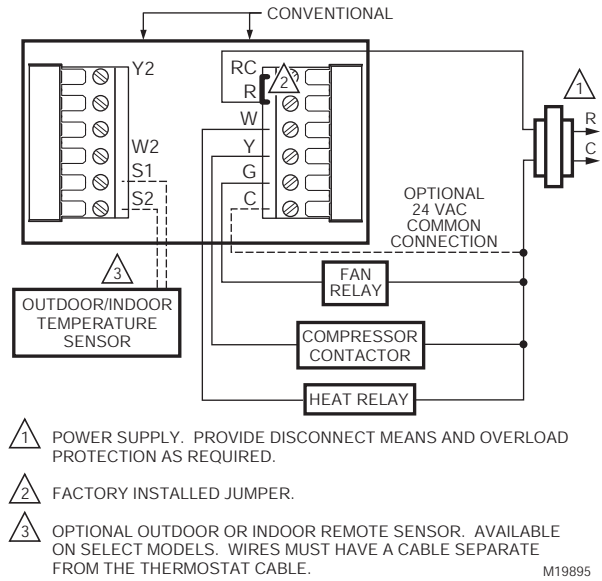

Fig. 9. Typical hookup of conventional single-stage heat and cool system with single transformer (1H/1C conventional).

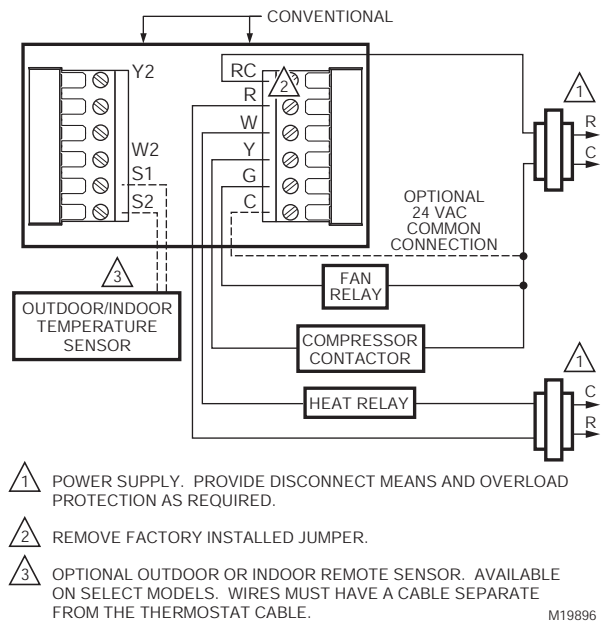

Fig. 10. Typical hookup of conventional single-stage heat and cool system with two transformers (1H/1C conventional).

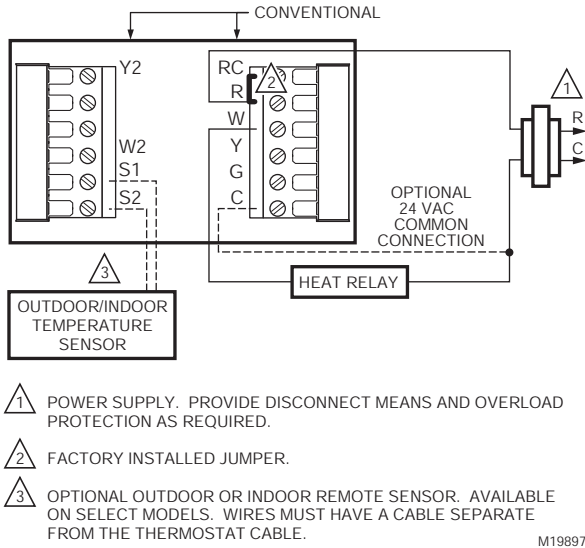

Fig. 11. Typical hookup of heat-only system (1 H conventional).

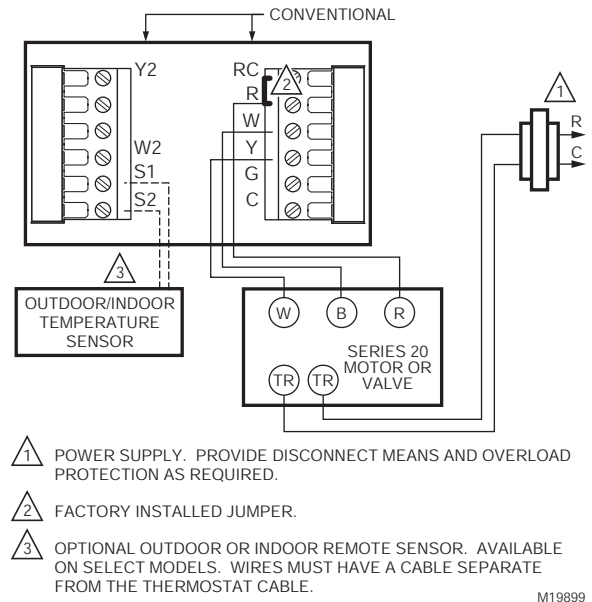

Fig. 13. Typical hookup of heat only power to open and power to close zone valve (Series 20) system.

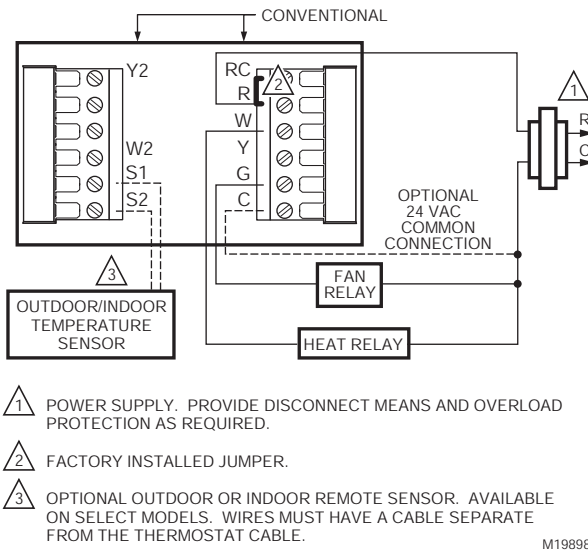

Fig. 12. Typical hookup of heat only system with fan (1H conventional).

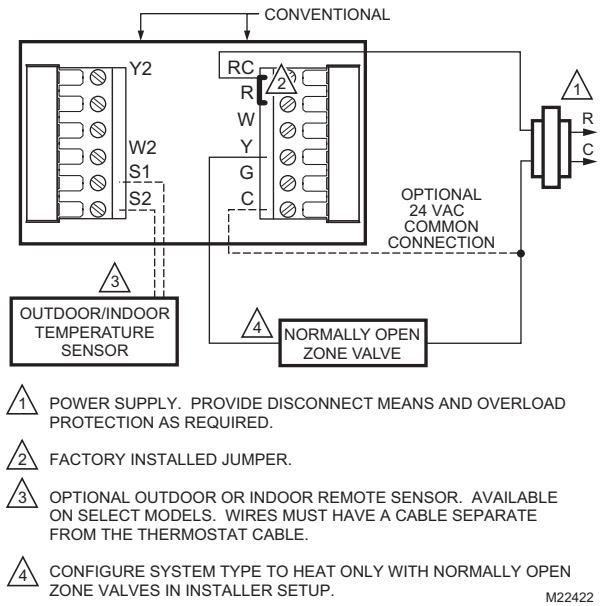

Fig. 14. Typical hookup of heat only system with normally open zone valves.

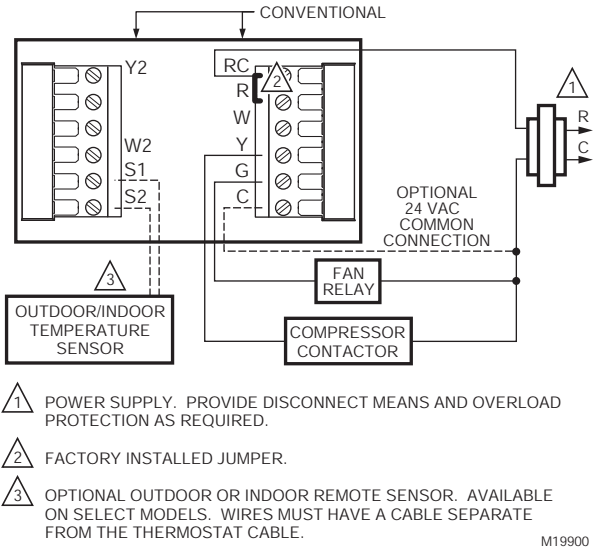

Fig. 15. Typical hookup of cool only system (1C conventional).

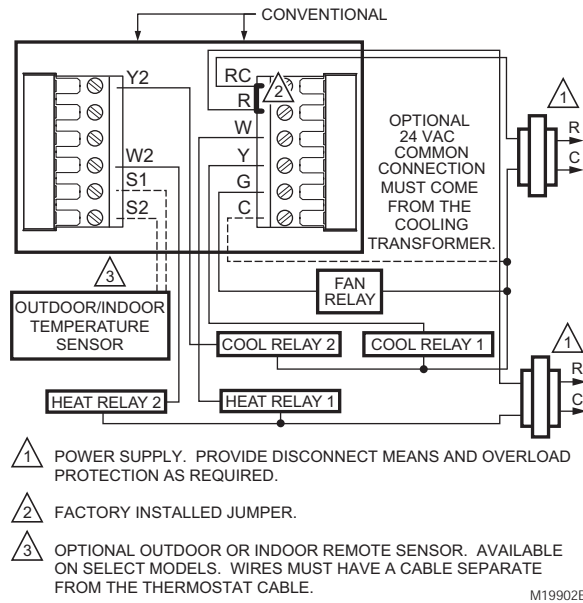

Fig. 17. Typical hookup of conventional multistage two-stage heating and two-stage cooling in a two-transformer system (2H/2C, 2H/1C or 1H/2C conventional).

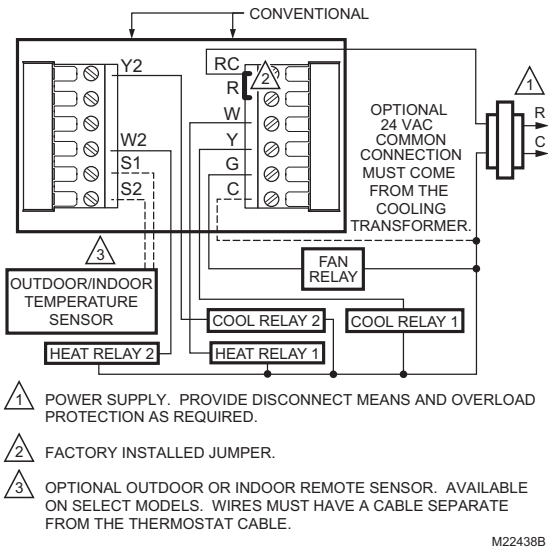

Fig. 16. Typical hookup of conventional multistage two-stage heating and two-stage cooling in a single-transformer system (2H/2C, 2H/1C or 1H/2C conventional).

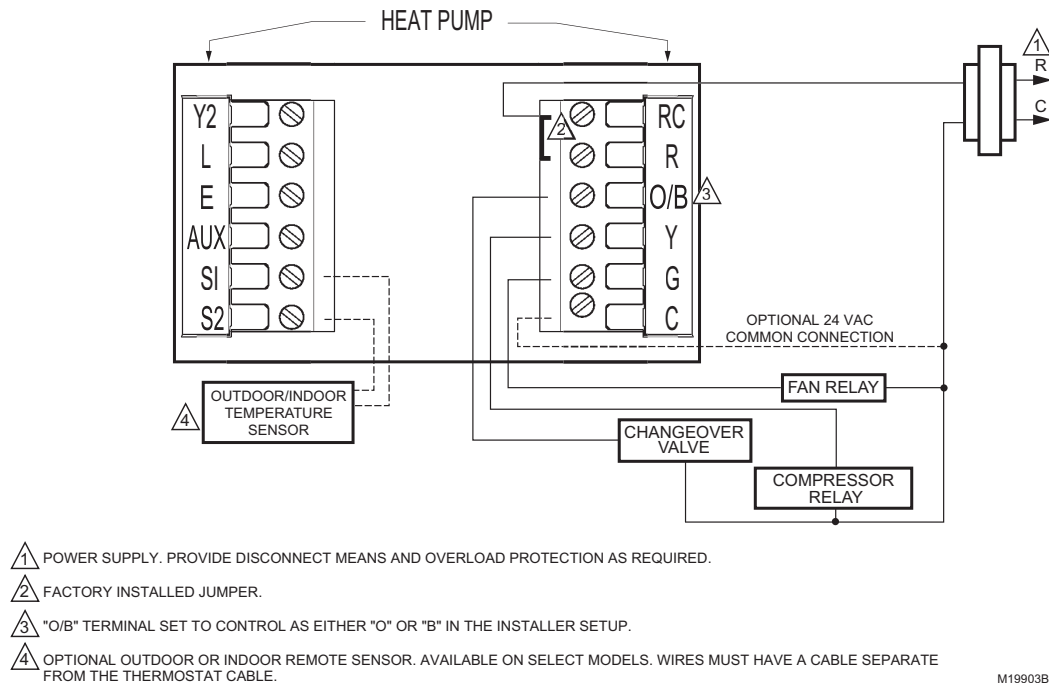

Fig. 18. Typical hookup of single-stage heat pump with no auxiliary/backup heat (1H/1C heat pump).

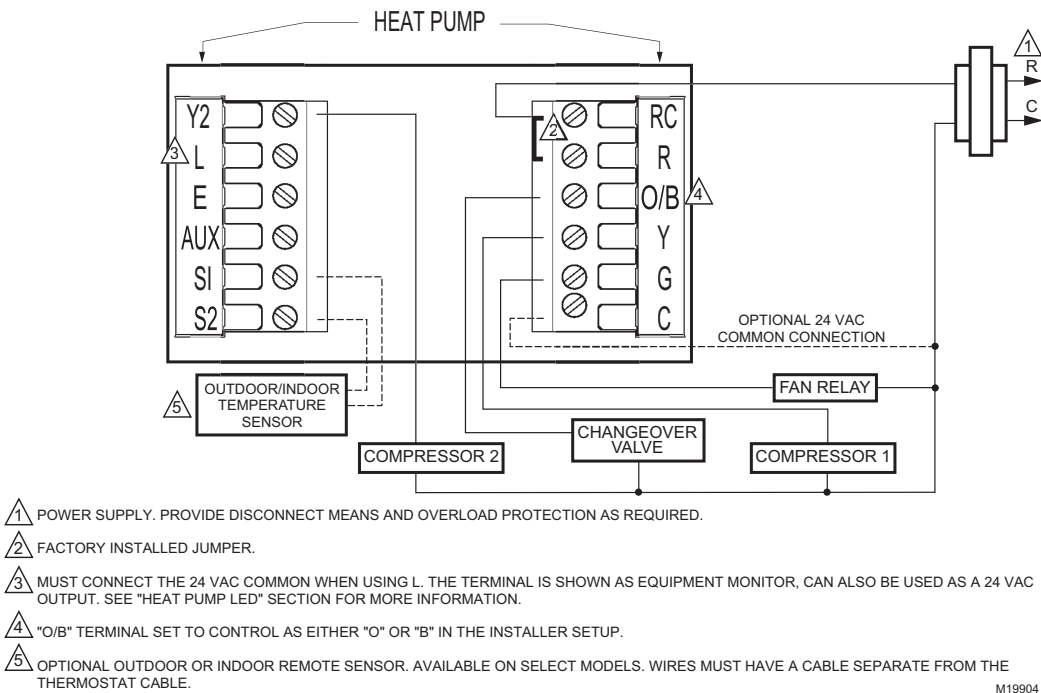
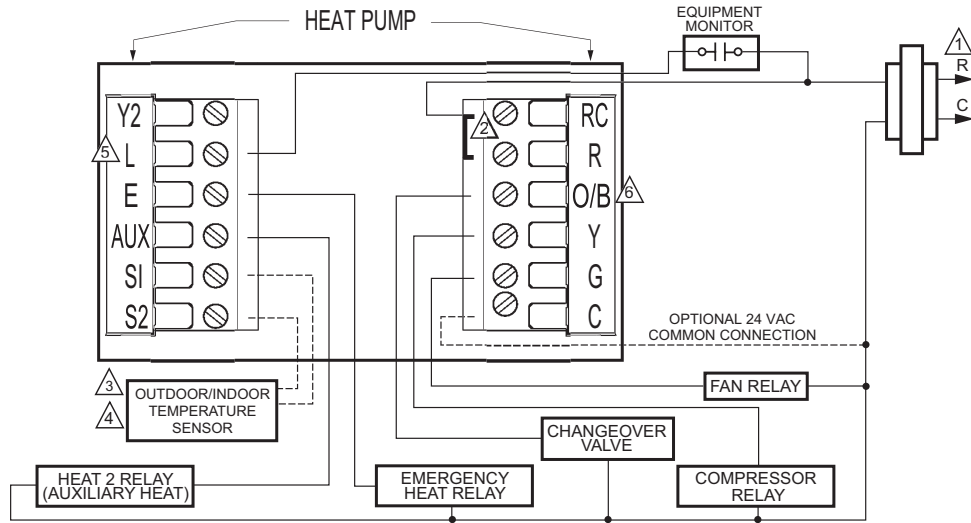

Fig. 19. Typical hookup of multistage heat pump with no auxiliary/backup heat (2H/2C heat pump).



- ⚠️ 1 POWER SUPPLY. PROVIDE DISCONNECT MEANS AND OVERLOAD PROTECTION AS REQUIRED.
- ⚠️ 2 FACTORY INSTALLED JUMPER.
- ⚠️ 3 OUTDOOR SENSOR REQUIRED IN SYSTEM WITH FOSSIL FUEL BACKUP HEAT THAT IS NOT USING AN EXTERNAL FOSSIL FUEL KIT.
- ⚠️ 4 OPTIONAL OUTDOOR OR INDOOR REMOTE SENSOR. AVAILABLE ON SELECT MODELS. WIRES MUST HAVE A CABLE SEPARATE FROM THE THERMOSTAT CABLE.
- ⚠️ 5 MUST CONNECT THE 24 VAC COMMON WHEN USING L. THE TERMINAL IS SHOWN AS EQUIPMENT MONITOR, CAN ALSO BE USED AS A 24 VAC OUTPUT. SEE "HEAT PUMP LED" SECTION FOR MORE INFORMATION.
- ⚠️ 6 "O/B" TERMINAL SET TO CONTROL AS EITHER "O" OR "B" IN THE INSTALLER SETUP.

M19905

Fig. 20. Typical hookup of single-stage heat pump with auxiliary/backup heat (2H/1C heat pump).

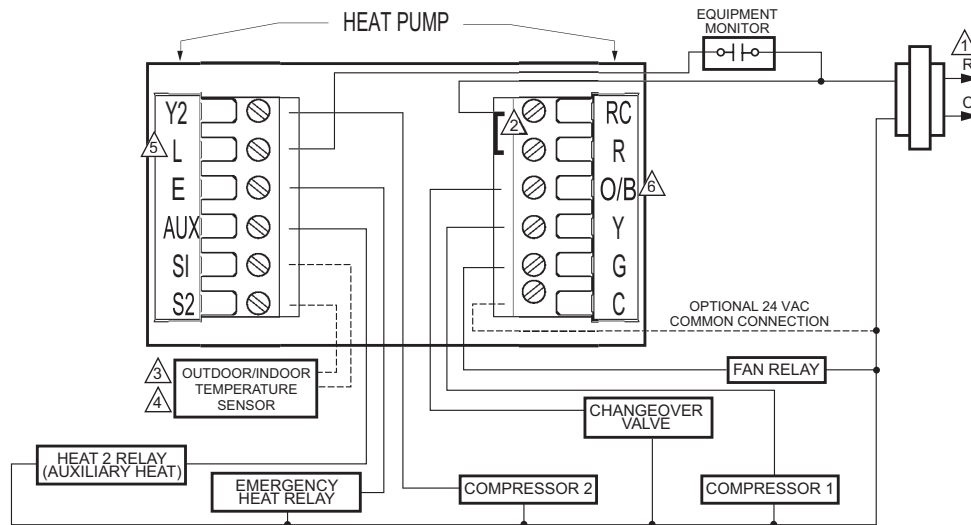

- ⚠️ 1 POWER SUPPLY. PROVIDE DISCONNECT MEANS AND OVERLOAD PROTECTION AS REQUIRED.
- ⚠️ 2 FACTORY INSTALLED JUMPER.
- ⚠️ 3 OUTDOOR SENSOR REQUIRED IN SYSTEM WITH FOSSIL FUEL BACKUP HEAT THAT IS NOT USING AN EXTERNAL FOSSIL FUEL KIT.
- ⚠️ 4 OPTIONAL OUTDOOR OR INDOOR REMOTE SENSOR. AVAILABLE ON SELECT MODELS. WIRES MUST HAVE A CABLE SEPARATE FROM THE THERMOSTAT CABLE.
- ⚠️ 5 MUST CONNECT THE 24 VAC COMMON WHEN USING L. THE TERMINAL IS SHOWN AS EQUIPMENT MONITOR, CAN ALSO BE USED AS A 24 VAC OUTPUT. SEE "HEAT PUMP LED" SECTION FOR MORE INFORMATION.
- ⚠️ 6 "O/B" TERMINAL SET TO CONTROL AS EITHER "O" OR "B" IN THE INSTALLER SETUP.

M19906

Fig. 21. Typical hookup of multistage heat pump with auxiliary/backup heat (3H/2C heat pump).

POWER THE THERMOSTAT

You can choose from three methods to power the thermostat:

- Batteries only (AAA alkaline).
- 24 Vac common wire only.
- 24 Vac common wire with battery backup (AAA alkaline).

Wiring 24 Vac Common

- Single-Transformer System—Connect the common side of the transformer to the C screw terminal of the thermostat wallplate. Leave the metal jumper wire in place between Rc and R.
- Two-Transformer System—Connect the common side of the cooling transformer to the C screw terminal of the thermostat wallplate. Remove the metal jumper wire between Rc and R.

Installing Batteries

1. Install three AAA alkaline batteries on the back of the thermostat as marked on the thermostat. See Fig. 22.

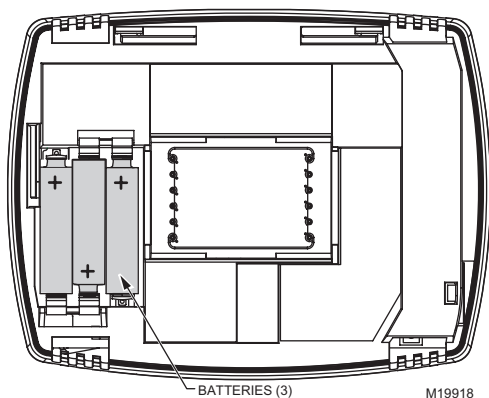

Fig. 22. Installing batteries.

2. Locate and remove the tab labeled, Remove, in the lower left corner on the thermostat back. See Fig. 23.

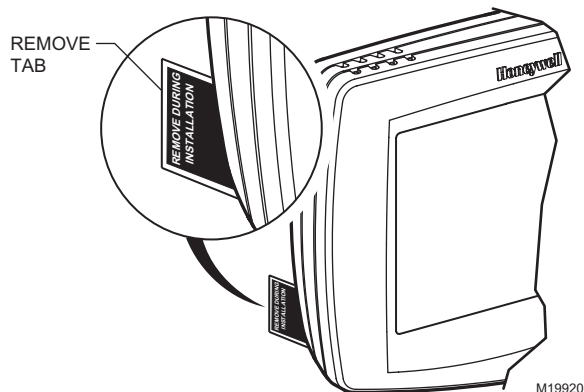

Fig. 23. Remove tab labeled, Remove, on thermostat back.

Mount Thermostat to Wallplate

1. Align the terminal screw blocks with the pins on the back of the thermostat. Push the thermostat straight onto the wallplate until it snaps into place. See Fig 24.

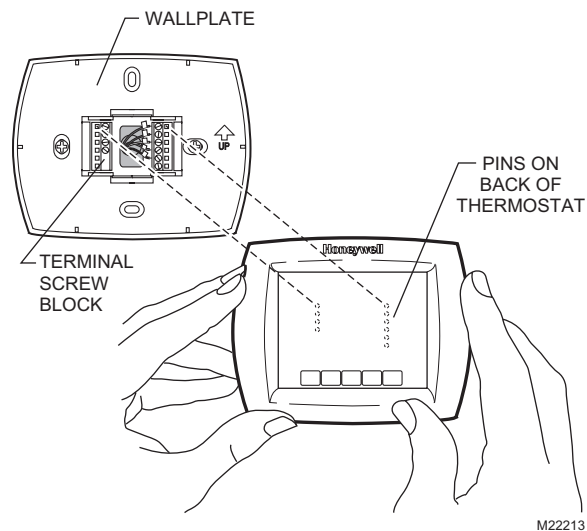

Fig. 24. Mount thermostat to wallplate.

Locate and Mount C7089U Outdoor Temperature Sensor (Optional)

Mount the sensor where (see Fig. 25):

- cannot tamper with settings.
- there is good air circulation.
- it can measure true outdoor ambient temperature.
- surface is flat.
- wire distance between C7089 and thermostat is less than 200 feet.

Do *not* mount the sensor:

- in direct sunlight.
- where hot or cold air blows on the sensor. Discharge line from an outdoor compressor unit, vent or fan causes inaccurate temperature readings.
- where snow, ice or debris can cover it.

Use the following steps to mount the sensor:

1. Remove the sensor from the mounting clip.
2. Mark the area on the location selected for mounting the sensor mounting clip.
3. Mount the clip.

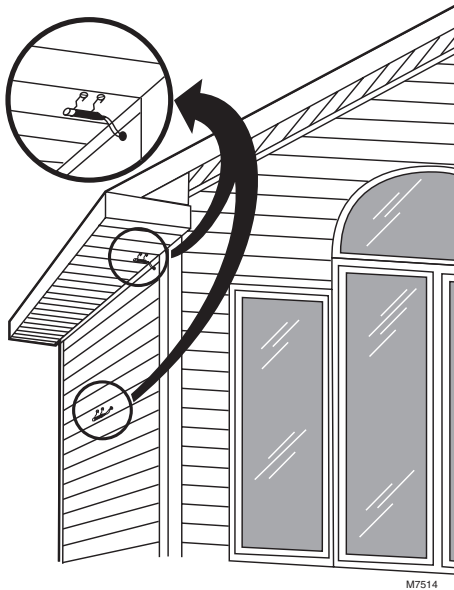

Fig. 25. Typical locations for C7089U Outdoor Sensor.

Wire C7089U Outdoor Sensor

⚠ CAUTION

Electrical Interference (Noise) Hazard.
Can cause erratic system operation.

Keep wiring at least one foot away from large inductive loads such as motors, line starters, lighting ballasts and large power distribution panels. Use shielded cable to reduce interference when rerouting is not possible.

IMPORTANT

Erratic temperature readings from a sensor can occur as a result of any of the wiring practices described below. Avoid these practices to assure correct operation. Use shielded cable to reduce interference if rerouting sensor wiring is not possible.

- Be sure wires have a cable separate from the thermostat cable.
- Do not route temperature sensor wiring with building power wiring, next to control contactors or near light dimming circuits, electric motors or welding equipment.
- Avoid poor wiring connections.
- Avoid intermittent or missing building earth ground.



CAUTION

Electrical Shock Hazard.

Can cause electrical shock or equipment damage.
Disconnect power supply before connecting wiring.

Wiring must comply with applicable codes, ordinances and regulations:

1. Wire C7089 Outdoor Sensor to S1 and S2 terminals on the thermostat. If leadwire provided is not long enough (60 in.), run a cable to a hole at C7089 location.
 - a. Using color-coded, 18-gauge thermostat wire is recommended. For example of general wiring of C7089, see Fig. 26.
 - b. Pigtail wiring can be used.
2. Mount C7089 in its mounting clip.
3. Plug wiring hole using nonhardening caulk or putty.

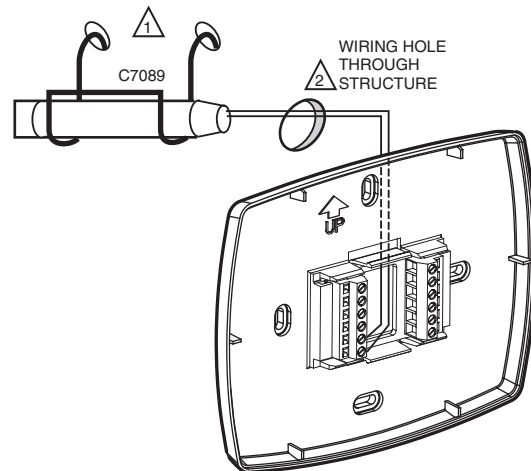

- ⚠ USE APPROPRIATE MOUNTING MEANS FOR THE TYPE OF STRUCTURE.
- ⚠ PLUG WIRING HOLE WITH NON-HARDENING CAULK OR PUTTY.

Fig. 26. Wire C7089 Outdoor Sensor to the thermostat.

Locate and Mount C7189U Remote Indoor Temperature Sensor (Optional)

- Choose a location (see Fig. 27) for mounting the sensor on an inside wall about 5 ft (1.5m) above the floor. A vertically-mounted standard 2 x 4 in. (51 x 102 mm) junction box can also be used.
- Be sure wire distance between C7189 and thermostat is less than 200 feet.
- Make sure there is good air circulation at average temperature at the chosen location. Avoid the following locations because they can introduce errors in sensor measurements. See Fig. 27.
 - Hot areas caused by:
 - Concealed pipes or ducts.
 - Drafts from fireplaces or other heat sources.
 - Convection or radiant heat from the sun or electrical equipment.
 - Cold areas caused by:
 - Concealed pipes or ducts.
 - Drafts from windows and doors.
 - Unheated areas on the other side of the wall location.
 - Dead air areas:
 - Behind doors, furniture and curtains.
 - In corners and alcoves.
- Mark the area on the wall selected for mounting the C7189 Sensor or junction box.
- Run wire cable to a hole at the selected wall location. Pull approximately three inches of wire through the opening. Color-coded, 18-gauge thermostat wire is recommended.

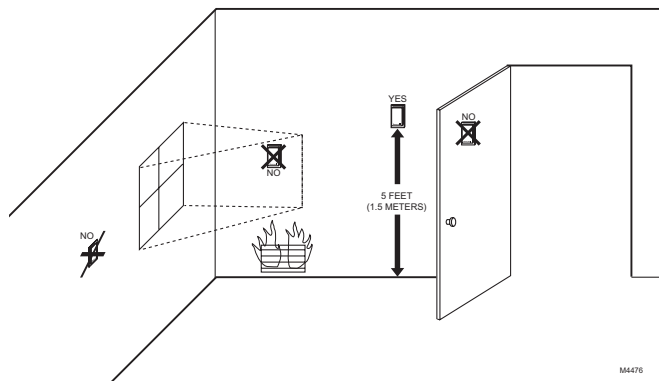

Fig. 27. Typical location for C7189 Indoor Sensor.

Wire C7189 Indoor Sensor



CAUTION

Electrical Interference (Noise) Hazard.

Can cause erratic system operation.

Keep wiring at least one foot away from large inductive loads such as motors, line starters, lighting ballasts and large power distribution panels.

IMPORTANT

Erratic temperature readings from a sensor can occur as a result of any of the wiring practices described below. Avoid these practices to assure correct operation.

- Be sure wires have a cable separate from the thermostat cable.
- Do not route temperature sensor wiring with building power wiring, next to control contactors or near light dimming circuits, electric motors or welding equipment.
- Avoid poor wiring connections.
- Avoid intermittent or missing building earth ground.



CAUTION

Electrical Shock Hazard.

Can cause electrical shock or equipment damage.

Disconnect power supply before connecting wiring.

Wiring must comply with applicable codes, ordinances and regulations.

- Wire C7189 Indoor Sensor to S1 and S2 terminals on the thermostat. For an example of general wiring of C7189, see Fig. 28 to wire one sensor and 29 to wire multiple sensors.
- Push excess wire back into the hole. Plug the hole using nonhardening caulk, putty or insulation to prevent drafts from affecting performance.
- Remove C7189 cover.
- Mount C7189 to the wall or junction box using the screws and anchors provided.
- Level the C7189 for appearance only. Device functions correctly even when not level.
- Install C7189 cover.

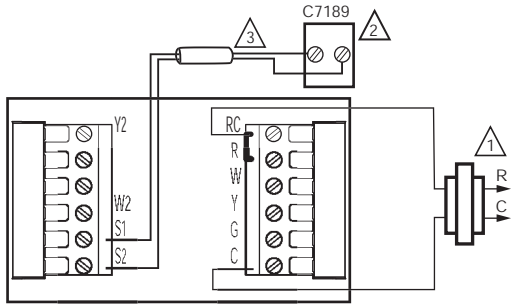

- 1 POWER SUPPLY. PROVIDE DISCONNECT MEANS AND OVERLOAD PROTECTION AS REQUIRED.
- 2 IF MORE THAN ONE C7189 REMOTE SENSOR IS REQUIRED, REFER TO FIGURE 3.
- 3 WIRES MUST HAVE A CABLE SEPARATE FROM THE THERMOSTAT CABLE.

M19972

Fig. 28. Wiring a single C7189 Indoor Sensor.

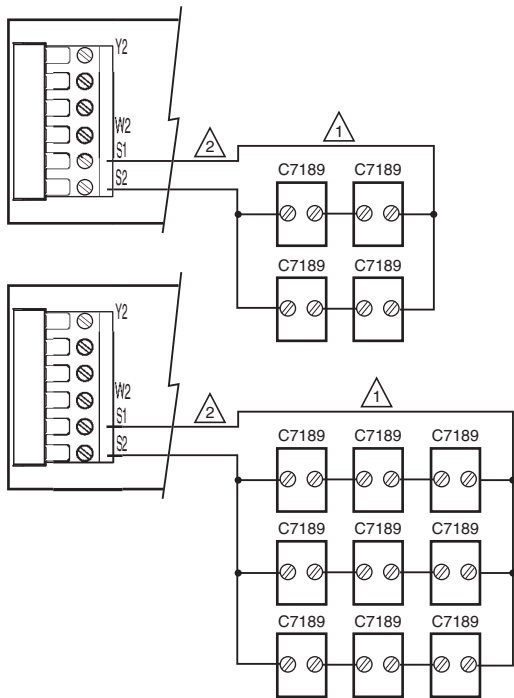

- 1 SENSORS MUST BE ARRANGED IN THIS CONFIGURATION TO OPERATE CORRECTLY.
- 2 WIRES MUST HAVE A CABLE SEPARATE FROM THE THERMOSTAT CABLE.

M19973

Fig. 29. Wiring Multiple C7189 Sensors.

Set Calendar and Time

Thermostat keeps current time and day for up to ten years under normal use after the calendar is set.

When the thermostat is first powered, the display is ready to set the calendar and time.

NOTE: Calendar can also be set in the Installer Setup.

1. Press the arrow keys to set the year, month and day.
2. Press the Done key.

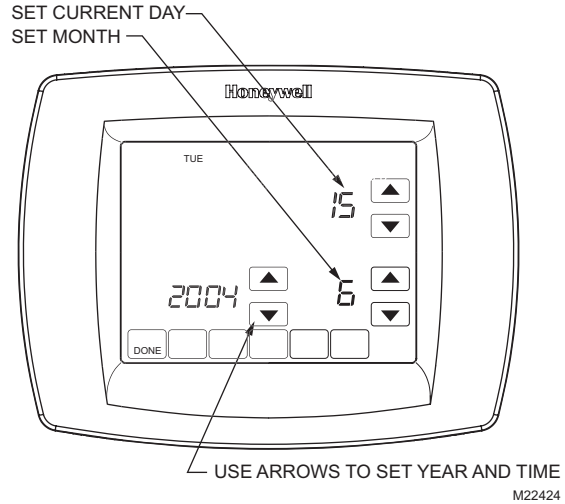

M22424

3. Press the arrow keys to set the current time.
4. Press the Done Key.

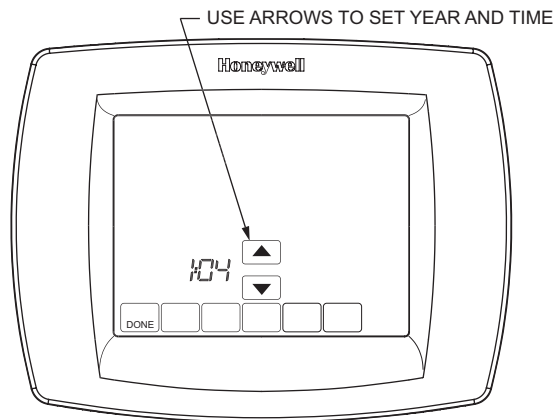

M22425

INSTALLER SETUP

Follow these steps to enter the Installer Setup:

1. Press and release the System Key.

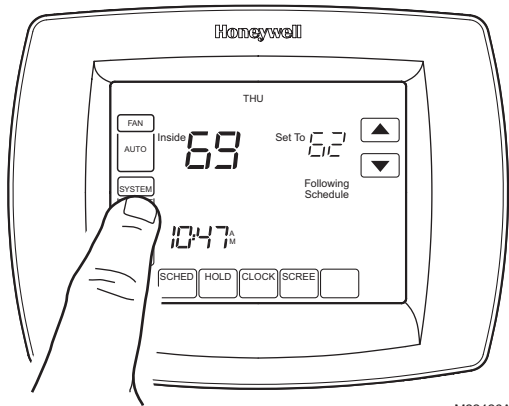

M22426A

2. Press and hold the two blank keys on either side of the center blank key for approximately five seconds until screen changes.

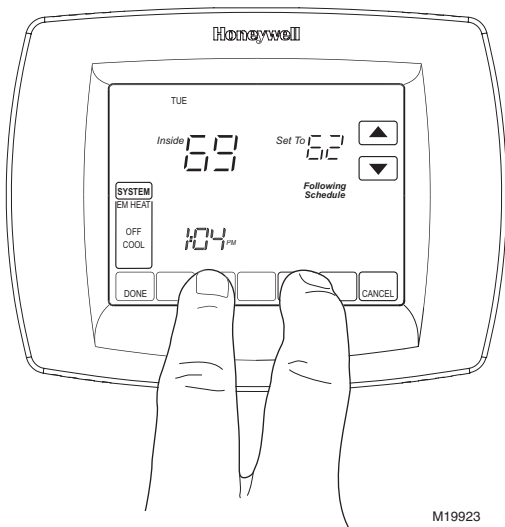

M19923

3. Release the two blank keys when the screen on the thermostat matches the screen below.

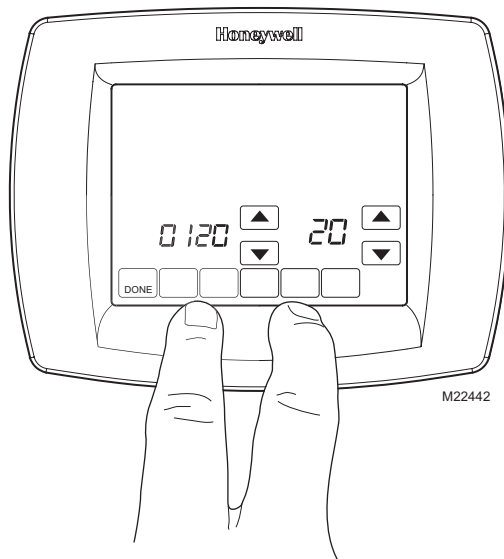

M22442

4. See screen below to review how the thermostat keys are used during Installer Setup. See Tables 3-5 for the Installer Setup Numbers and Settings.

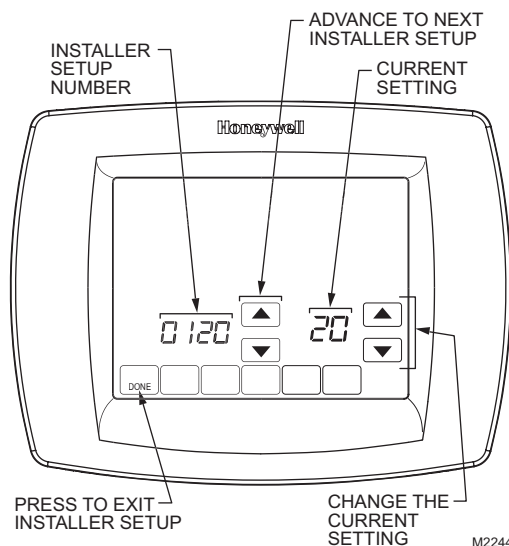

M22443

5. Press the Done key to exit the Installer Setup screen.

Table 3. Installer Setup Menu.

Installer Setup Number	Installer Setup Name	Settings	Notes
0120	Date (Year Upper)	Select first two digits of current calendar year (2005 , etc)	2001 - 2178 available
0130	Date (Year Lower)	Select last two digits of current calendar year (05 for year 2005, etc)	2001 - 2178 available
0140	Date (Month)	Select number that represents current calendar month	—
0150	Date (Day)	Select number that represents current calendar date	—
0160	Schedule Options	0 —nonprogrammable 4 —7-day programmable	—
0170	System Type Selection	1 —1 heat/1 cool conventional (factory setting) 2 —single-stage heat pump (no auxiliary heat) 3 —heat only conventional (no fan) Also for 750mV. 4 —heat only conventional (with fan) 5 —heat only (power to open and power to close zone valves or normally-open zone valves) 6 —cool only conventional 7 —2 heat/1 cool heat pump (with auxiliary heat) 8 —2 heat/2 cool multistage conventional 9 —2 heat/1 cool multistage conventional 10 —1 heat/2 cool multistage conventional 11 —2 heat/2cool heat pump (no auxiliary heat) 12 —3 heat/2cool heat pump (with auxiliary heat)	Available options and defaults vary by thermostat. System selection automatically modifies some default settings and/or hides other Installer Setup options.
0180	Fan Control in Heating	0 —gas or oil furnace equipment controls fan in heating (factory setting) 1 —electric furnace—thermostat controls fan in heating	Only shown if conventional system is selected. If heat pump is chosen, fan defaults to electric.
0190	Changeover Valve—O/B Terminal Energized in Heating or Cooling (Heat Pumps Only)	0 —changeover valve—O/B terminal is energized in cooling (factory setting) 1 —changeover valve—O/B terminal is energized in heating	Only shown if heat pump system is chosen.
0200	Backup Heat Source (Auxiliary Heat)	0 —heat pump backup heat source is electric (factory setting) 1 —heat pump backup heat source is fossil fuel	Only shown if 2 heat/1 cool or 3 heat/2 cool heat pump is chosen
0210	External Fuel Fossil Fuel Kit	0 —no external fossil fuel kit is controlling heat pump backup heat. This thermostat controls the dual fuel. Must install outdoor sensor and set Installer Setup Number 0340 to number 2. 1 —external fossil fuel kit is controlling heat pump backup heat	Only shown if fossil fuel is chosen as backup heat source.
0220	Cycles per hour (cph) for 1st Stage Compressor	3 —cph recommended for compressors (factory setting) 1, 2, 4, 5, 6 —other cycle rate settings	—
0230	Cycles per hour (cph) for 2nd Stage Compressor	3 —cph recommended for compressors (factory setting) 1, 2, 4, 5, 6 —other cycle rate settings	Only shown if two stages of cool are selected.
0240	Cycles per hour (cph) for 1st Stage Conventional Heat	1 — 1 cph used for steam and gravity 3 —3 cph used for hot water system and high efficiency (90% or better) furnaces 5 —5 cph used for standard fossil fuel forced air (less than 80% efficient) systems (factory setting) 9 —9 cph used for electric furnaces 2, 4, 6, 7, 8, 10, 11, 12 —other cycle rate settings	Not shown if system selection is heat pump. Selection in this stage changes default cph for 2nd stage heat.
0250	Cycles per hour (cph) for 2nd Stage Heat (Aux Heat for 2H/1C Heat Pumps)	1 —1 cph used for steam and gravity 3 —3 cph for hot water systems and high efficiency (90% or better) furnaces 5 —5 cph for standard fossil fuel forced air (less than 90% efficient) systems (factory setting) 9 —9 cph used for electric furnaces or electric auxiliary heat for heat pump systems 2, 4, 6, 7, 8, 10, 11, 12 —other cycle rate settings	Only shown if two stages of heat are selected.

Table 3. Installer Setup Menu. (Continued)

Installer Setup Number	Installer Setup Name	Settings	Notes
0260	Cycles per hour (cph) for 3rd Stage Heat (Aux Heat for 3H/2C Heat Pumps)	<p>1—1 cph used for steam and gravity</p> <p>3—3 cph for hot water systems and high efficiency (90% or better) furnaces</p> <p>5—5 cph for standard fossil fuel forced air (less than 90% efficient) systems (factory setting)</p> <p>9—9 cph used for electric furnaces or electric auxiliary heat for heat pump systems</p> <p>2, 4, 6, 7, 8, 10, 11, 12—other cycle rate settings</p>	Only shown if 3H/2C heat pump is selected.
0270	Cycles per hour (cph) for Em Heat	<p>3—3 cph for hot water systems and high efficiency (90% or better) furnaces</p> <p>5—5 cph for standard fossil fuel forced air (less than 90% efficient or better) systems</p> <p>9—9 cph for electric strip heat for heat pumps</p>	Only shown if 2H/1C or 3H/2C heat pump is selected.
0280	Continuous Backlight	<p>0—Backlight not on continuously. Thermostat backlight comes on with each key press.</p> <p>1—Backlight is on continuously (thermostat must have a common wire attached for this function).</p>	Option is always shown; however, continuously on backlight works only if thermostat is wired with 24 Vac Common.
0300	Changeover	<p>0—manual changeover (factory setting)</p> <p>1—auto changeover</p>	—
0310	Deadband	<p>Heating and cooling setpoints can be set no closer than chosen value:</p> <p>2—2° F (1.5° C)</p> <p>3—3° F (2° C)</p> <p>4—4° F (2.5° C)</p> <p>5—5° F (3° C)</p> <p>6—6° F (3.5° C)</p> <p>7—7° F (4° C)</p> <p>8—8° F (4.5° C)</p> <p>9—9° F (5° C)</p>	Shown only if automatic changeover is selected.
0320	Temperature Indication Scale	<p>0—fahrenheit temperature display (factory setting)</p> <p>1—celsius temperature display</p>	—
0330	Daylight Savings	<p>1—daylight savings is on (factory setting).</p> <p>0—daylight savings is off.</p>	Set to 0 in areas that do not follow daylight savings.
0340	Remote Temperature Sensor (Outdoor or Indoor)	<p>0—no remote temperature sensor</p> <p>1—outdoor temperature sensor for display only.</p> <p>2—outdoor temperature sensor for control. Outdoor sensor used for Heat Pump Lockout settings. (See Heat Pump Temperature Lockout section for more details.)</p> <p>3—indoor temperature sensor</p>	<p>Defaults and Options depend on System Type selection.</p> <p>Indoor Temperature Sensor uses an averaging network and does not include on-board sensor.</p>
0350	Heat Pump Compressor Lockout or (Balance Point)	<p>0—no compressor lockout.</p> <p>15° F (-9.5° C)</p> <p>20° F (-6.5° C)</p> <p>25° F (-4° C)</p> <p>30° F (-1° C)</p> <p>35° F (1.5° C)</p> <p>40° F (4.5° C)</p> <p>45° F (7° C)</p>	Default depends on other selections. Shown if Outdoor Temperature for control is selected. (See Advanced Features section for more information.)

Table 3. Installer Setup Menu. (Continued)

Installer Setup Number	Installer Setup Name	Settings	Notes
0360	Heat Pump Auxiliary Lockout	0 —no auxiliary heat lockout. 40°F (4.5°C) 45°F (7°C) 50°F (10°C) 55°F (13°C) 60°F (15.5°C)	Shown if electric is chosen for backup heat source and outdoor temperature sensor for control is selected. (See Advanced Features section for more information.)
0380	Indoor Dehumidification Control	0 —No indoor dehumidification control. 1 —Dehumidification control activated.	Available on select models. If dehumidification control is activated and auto-changeover is selected in Installer Setup Number 0300, the deadband minimum is defaulted to 5°F (3°C) in Number 0310.
0500	Furnace Change Reminder	0 —furnace filter reminder off 1 —10 run time days 2 —30 run time days 3 —60 run time days 4 —90 run time days 5 —120 run time days 6 —365 run time days	Run time based on call for fan.
0510	Humidifier Pad Replacement Reminder	0 —humidifier pad replacement reminder off 1 —90 calendar days 2 —180 calendar days 3 —365 calendar days	—
0520	UV Lamp Replacement Reminder	0 —UV lamp replacement reminder off 1 —365 calendar days	—
0530	Adaptive Intelligent Recovery™	1 —Adaptive Intelligent Recovery™ control is activated (system starts early so setpoint is reached by start of program period). 0 —Conventional Recovery (system starts recovery at programmed time)	—
0540	Number of Periods	2 —two periods available (Wake and Sleep) 4 —four periods available (Wake, Leave, Return and Sleep)	Not shown if non-programmable is selected. 2 or 4 applies to all days of the week.
0580	Minimum Compressor Off Time	5 —five-minute compressor off-time setting (factory setting) 0, 2, 3, 4 —other compressor off-time settings	—
0600	Heat Temperature Range Stop	40-90 —temperature range (1°F increments) of heating setpoint.	Shown in 1/2 °C.
0610	Cool Temperature Range Stop	50-99 —temperature range (1°F increments) of cooling setpoint.	Shown in 1/2 °C.
0640	Clock Format	12 —12 hour clock (factory setting) 24 —24 hour clock	—

Table 3. Installer Setup Menu. (Continued)

Installer Setup Number	Installer Setup Name	Settings	Notes
0650	Extended Fan OnTime Heat	0 —no extended fan operation after call for heat ends 90 — fan operation is extended 90 seconds after call for heat ends.	Not shown if fan operation is set to fossil fuel or in Cool Only Systems
0660	Extended Fan On Time Cool	0 —no extended fan operation after call for cool ends 90 —fan operation is extended 90 seconds after call for cool ends.	Not shown in Heat Only Systems.
0670	Keypad Lockout	0 —unlocked keypad 1 —partially locked keypad 2 —fully locked keypad	Unlocked—all functions are available. Partially locked—only temperature up and down keys and ability to enter and modify Installer Setup mode are available. Fully locked—only ability to enter and modify Installer Setup mode are available.
0680	Temperature Control in Heat	1 —less aggressive temperature control (could cause temperature undershoot) 2 —Standard temperature control in heating (factory setting) 3 —more aggressive temperature control (could cause temperature overshoot)	Applies to recovery ramp and use of auxiliary heat during recovery. Choose 1 if getting temperature overshoot. Choose 3 if getting temperature undershoot.
0690	Temperature Control in Cool	1 —less aggressive temperature control (could cause temperature undershoot) 2 —Standard temperature control in cooling (factory setting) 3 —more aggressive temperature control (could cause temperature overshoot)	Applies to recovery ramp. Choose 1 if getting temperature overshoot. Choose 3 if getting temperature undershoot.
0700	Temperature Display Offset	-3 —°F (-1.5°C) -2 —°F (-1°C) -1 —°F (-.5°C) 0 —°F (0. °C) — (no difference in displayed temperature and actual room temperature) 1 —°F (.5°C) 2 —°F (1°C) 3 —°F (1.5°C)	—
0710	Reset Thermostat	0 —no thermostat reset. 1 —resets all Installer Setup Options to default values and resets schedule to default setting.	Only calendar settings and time are retained.

INSTALLER SYSTEM TEST

Use the Installer System Test to test the heating, cooling and fan (and emergency heat for heat pump systems).

CAUTION

Equipment Damage Hazard.
Minimum compressor off time is bypassed during Installer System Test
 Avoid cycling compressor quickly.

How to Use the Installer System Test

The Installer Test is part of the Installer Setup Menu.

1. Enter the Installer System Test by entering the Installer Setup.
2. Note that the test appears at the end of the Installer Setup Numbers.
3. See Fig. 30 to review how the thermostat buttons are used during the Installer System Test. See Table 6 for available Installer System Tests.

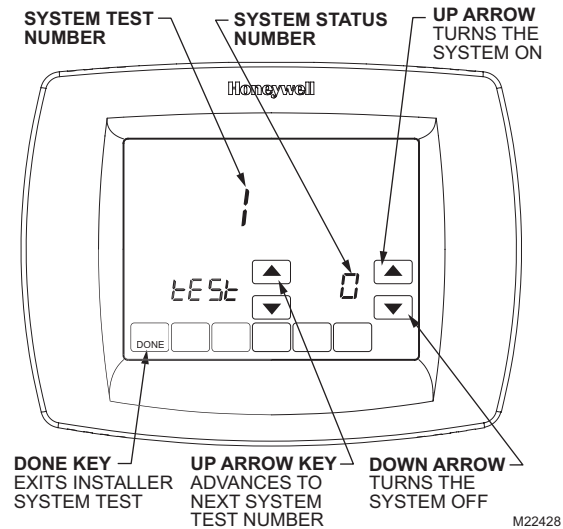

Fig. 30. Review thermostat buttons used during Installer System Test.

Installer System Tests

IMPORTANT

Use the Installer System Test to test the heating, cooling, fan and emergency heat. The setting you choose for System Type (Installer Setup Number 0170) may prevent some System Test Numbers from appearing.

Table 4. Installer System Test.

System Test Number	Test Type	System Status Number and Description
Test 1	Cooling System Test	1—Cool stage 1 turns on. 2—Cool stage 1 and stage 2 turn on. 0—Cool is off.
Test 2	Fan System Test	1—Fan turns on. 0—Fan turns off.
Test 3	Heating System Test	1—Heat stage 1 turns on. 2—Heat stage 1 and stage 2 (aux heat) turn on. 0—Heat is off.
Test 4	Emergency Heat Test	1—Emergency heat turns on. 2—Emergency heat and auxiliary heat turn on. 0—Emergency heat turns off.

Press the Next button to go to the beginning of the Installer Setup or press the Done button to exit the Installer System Test.

OPERATION

Thermostat Keys

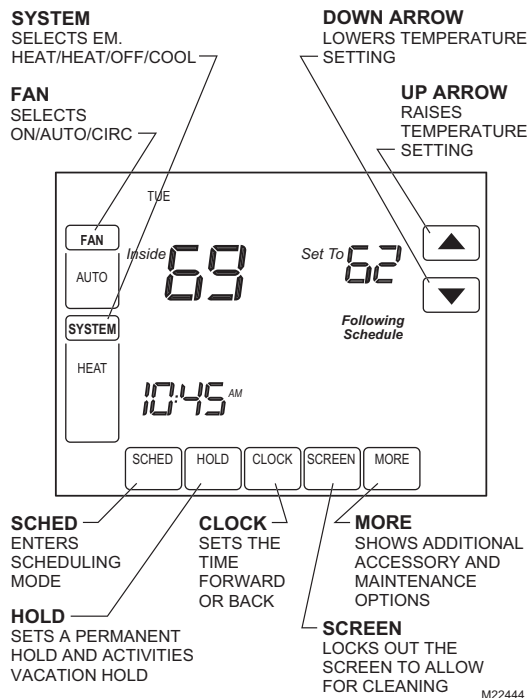

System and Fan Settings

System

The System key selections vary based on your heating and/or cooling system type.

Heat — Thermostat controls the heating system.

Off — Both heating and cooling systems are off.

Cool — Thermostat controls the cooling system.

Auto — Thermostat automatically changes between heating and cooling operation, depending on indoor temperature.

Em. Heat — Emergency heat cycles to maintain temperature. Compressor is locked out (used only for 2H/1C or 3H/2C heat pump systems) and auxiliary heat turns on as second stage if needed.

Fan

The Fan key selections vary based on the heating and/or cooling system type.

On — Fan runs continuously. Use this setting for improved air circulation or for more efficient central air cleaning.

Auto — fan follows the fan program schedule.

Circ — fan runs randomly approximately 35% of the time. Use this setting for improved air circulation or for more efficient central air cleaning when you do not want the fan running continuously.

User Setup

Follow these steps to enter the User Setup:

1. Press and release the System key.

Thermostat Display

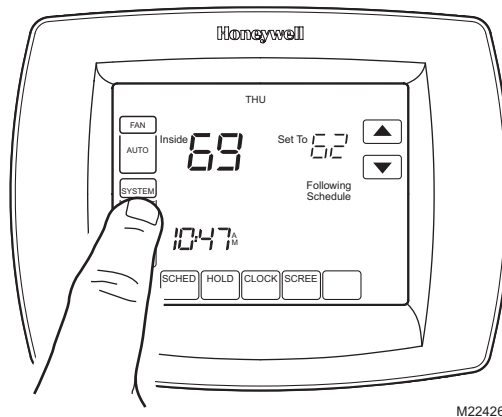
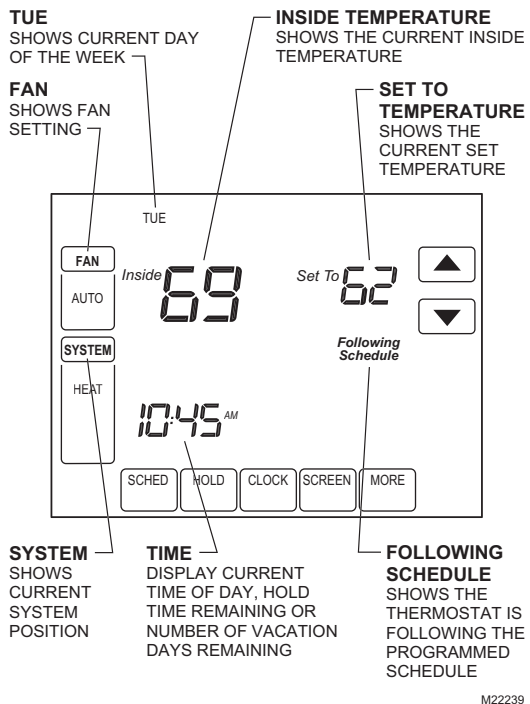

- Press and hold the center blank key for approximately five seconds until the screen changes.

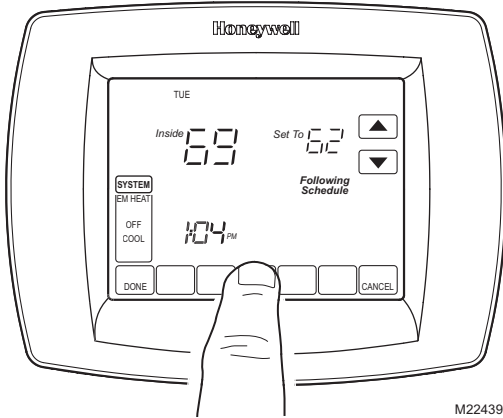

- Release the center blank key when the screen on the thermostat matches the screen below.

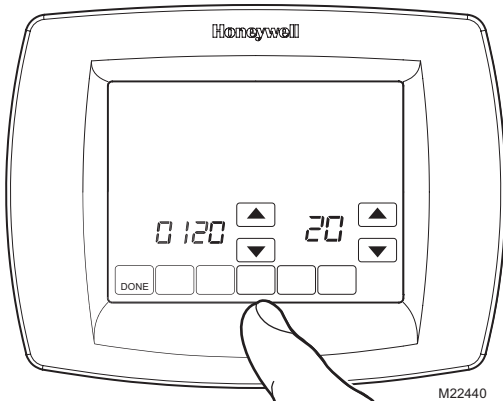

- See the screen below to review how the thermostat keys are used during the User Setup. See Table 5 for the User Setup numbers and settings.

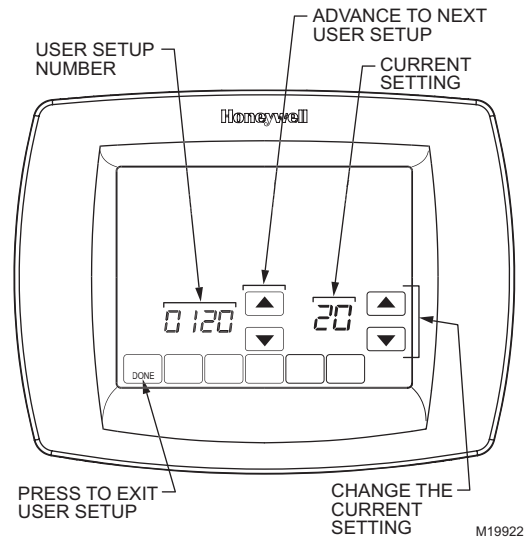

- Press the Done key to exit the User Setup screen.

Table 5. User Setup Settings.

User Setup Number	User Setup Name	Settings
0120	Date (first two digits of year)	Select first two digits of current calendar year (20 for year 2005 , etc)
0130	Date (last two digits of year)	Select last two digits of current calendar year (05 for year 2005 , etc)
0140	Date (month)	Select number of current calendar month (1-12)
0150	Date (day)	Select number of current calendar date (1-31)
0160	Schedule options	0 —Non-programmable 4 —7-day programmable (factory setting)
0320	Display temperature in °F or °C	0 —°F setting (factory setting) 1 —°C setting
0330	Daylight savings time	1 —Daylight savings is on (factory setting) 0 —Daylight savings is off

Table 5. User Setup Settings.

User Setup Number	User Setup Name	Settings
0500	Furnace air filter	0—off (factory setting) 1—10 fan run time days (about one month) 2—30 fan run time days (about three months) 3—60 fan run time days (about six months) 4—90 fan run time days (about nine months) 5—120 fan run time days (about one year) 6—365 fan run time days (about three years)
0510	Humidifier pad reminder	0—off 1—3 months 2—6 months 3—12 months
0520	UV lamp reminder	0—off (factory setting) 1—1 year
0540	Number of schedule periods available	2—two (Wake and Sleep) 4—four (Wake, Leave, Return, Sleep)—factory setting
0640	Clock format	12—12-hour clock (factory setting) 24—24-hour clock
0670	Screen lockout	0—all keys available; screen is unlocked (factory setting) 1—screen is partially locked. All key functions locked except Temperature Up and Down keys and Cancel key. 2—screen is fully locked

PROGRAMMING

Preprogrammed Energy Star Settings

Table 6 shows default program settings. Visit the Energy Star web site at www.energystar.gov for additional education and resources on programmable thermostats.

Table 6. Energy Star Default Program Settings.

Schedule Period	Time	Setpoints		Fan Setting
		Heat	Cool	
Wake	6:00AM	70°F (21°C)	78°F (25.5°C)	Auto
Leave	8:00AM	62°F (16.5°C)	85°F (29.5°C)	Auto
Return	6:00PM	70°F (21°C)	78°F (25.5°C)	Auto
Sleep	10:00PM	62°F (16.5°C)	82°F (28°C)	Auto

Program Heating and Cooling Schedule

Your thermostat can control up to four different schedule periods per day:

Wake—Period when you awaken and want your home at a comfortable temperature.

Leave—Period when you are away from home and want an energy-saving temperature.

Return—Period when you return home and want your home back to a comfortable temperature.

Sleep—Period when you are asleep and want an energy-saving temperature.

NOTE: Schedule times are in 15-minute intervals.

Edit Schedule

1. Press Sched key.

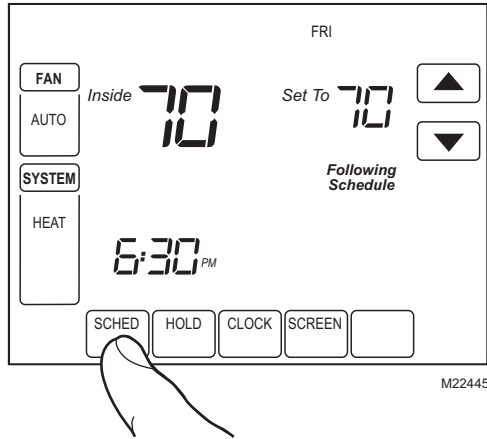

2. Press Edit key.

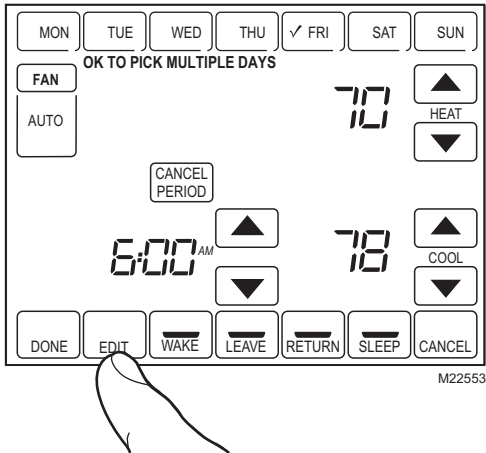

3. It is OK to pick multiple days. Select any combination of days to edit. These days are scheduled with the same times and temperatures. Check marks appear next to days selected.

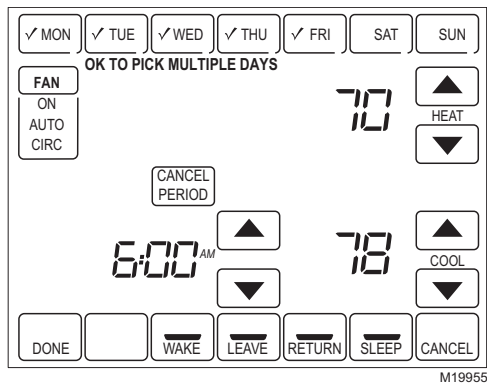

4. Press Wake key. Once pressed, Wake flashes to show it is selected.
5. Press Up and Down keys to modify time and heat and cool temperatures from this screen.

NOTE: The Fan setting can be programmed for On, Auto, or Circ for each period selected. See Fan Schedule section for more information.

6. Press Leave key and repeat step 5.
7. Press Return key and repeat step 5.
8. Press Sleep key and repeat step 5.
9. When complete, press Done key. "Saving Changes" appears on the screen to indicate changes are being saved to the day(s) modified.

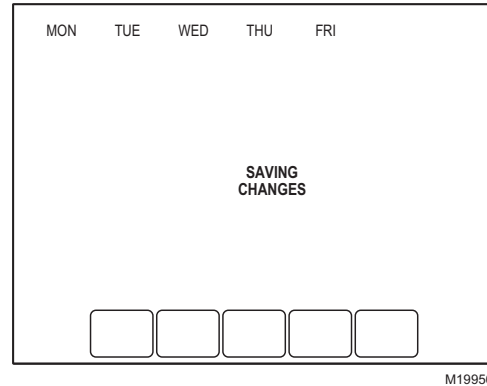

NOTE: To set a Program Schedule for the remaining days of the week, repeat steps 1-9. Example: If Mon - Fri was selected first, go back and repeat steps 1-9 for Sat and Sun.

10. To exit schedule without saving changes, press Cancel key any time.

Cancel a Schedule Period

1. Press Sched key.
2. Press Edit key.
3. Select the Day(s) of the week desired.
4. Press schedule period you want to cancel (Wake, Leave, Return or Sleep). Once selected, the period flashes.
5. Press Cancel Period key.

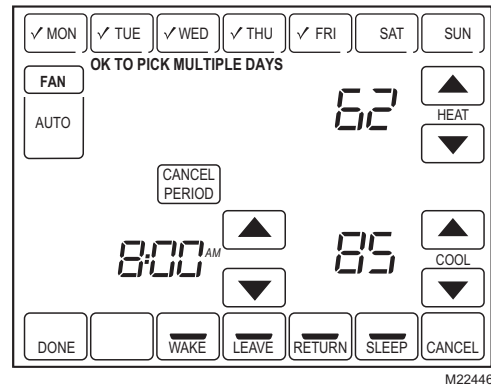

6. The time, temperature(s) and fan setting disappear. The bar above the selected period is removed, indicating the scheduled period was cancelled.

NOTE: To reinstate a schedule period, press arrow keys to set desired time and temperatures.

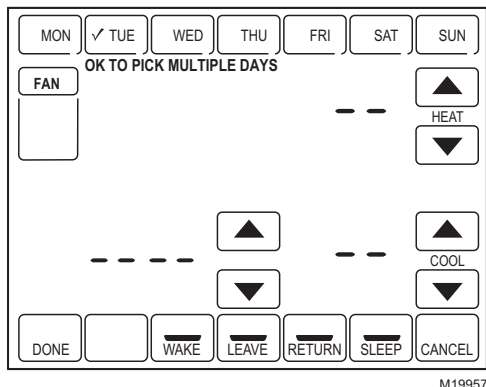

7. Press Done key.

Fan Schedule

Press Fan key while in the Scheduling Screen to program the System Fan. Choices available from the Scheduling Screen:

- Auto** (default position)—fan runs with equipment. Programmable for all schedule periods (Wake, Leave, Return and Sleep).
- On**—fan runs continuously (programmable for all schedule periods).
- Circ**—fan runs randomly for approximately 35% of schedule period (programmable for all schedule periods).

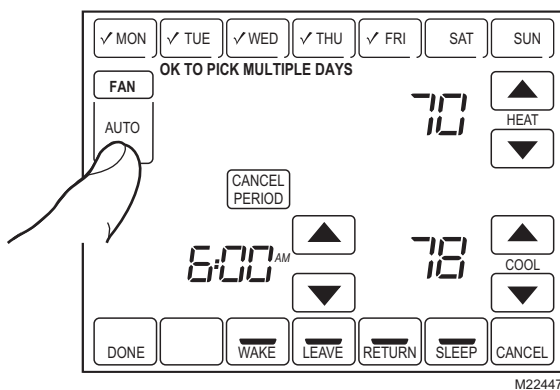

Fan Control (Table 7)

If the Fan program is scheduled, Auto is shown and any programmable mode that is set; for example, if during Wake period, Fan is set to Auto, only Auto is shown in the Fan area. However, if during the Wake period, fan is scheduled to On, both Auto and On are shown. Auto indicates fan is running its schedule; On indicates Fan schedule is set to On.

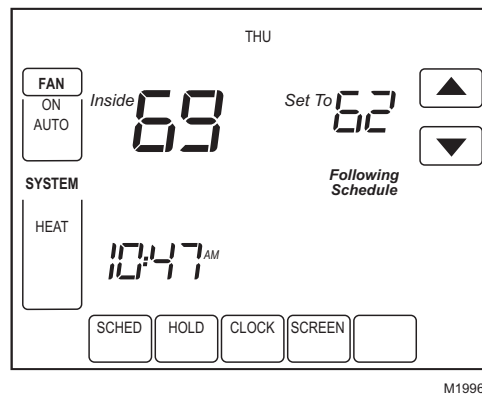

Table 7. Fan Program Operation and Screen Status.

Fan Setting	Fan Program Schedule	Call for Action	Energize Terminal	Fan Status shown on Screen
Auto	Auto	None	None	Auto
Auto	On	Fan	G	Auto/On
Auto	Circ	None	None	Auto/Circ
Auto	Circ	Fan	G	Auto/Circ

Manual Override of Fan Schedule (Table 8)

Auto—fan is automatically following the Fan schedule (choices are Auto, On or Circulate).

On—overrides Fan schedule. Fan is continuously On.

Circ—overrides Fan schedule. Fan circulates randomly for approximately 35% of time until the Auto position is selected.

Table 8. Manual Override of Fan Schedule Operation.

Fan Setting	Fan Schedule Override Setting	Call for Action	Energize Terminal	Screen Message Under Fan Setting
Auto	On	Fan	G	On
Auto	Circ	None	None	Circ
Auto	Circ	Fan	G	Circ
On	Auto ^a	—	—	—
On	Circ	None	None	Circ
On	Circ	Fan	G	Circ
Circ	Auto ^a	—	—	—
Circ	On	Fan	G	On

^aAuto Override resumes the Fan Program in each schedule period (Wake, Leave, Return and Sleep)

Operate VisionPRO™ 8000 Touchscreen

Set Time

1. Press Clock.
2. Use arrows to set current time.

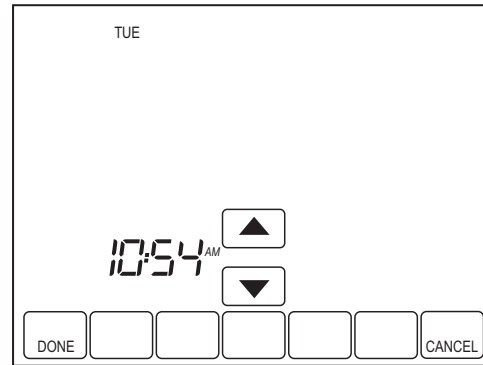

M19958

3. Press Done key.

IMPORTANT

The current day of the week should already be set correctly. If not, see Installer Setup to set the day.

Set Temperature Overrides

The thermostat has three temperature override options: Hold Temperature Until, Permanent Hold and Vacation Hold.

HOLD TEMPERATURE UNTIL (TEMPORARY HOLD)

Holds temperature temporarily until the next scheduled period time or until the time the user sets.

1. Press Up or Down arrow next to the temperature you want to adjust. "Hold Temperature Until" time appears on the screen. The Hold Temperature Until time defaults to the start time of the next scheduled period.

NOTE: The Time Up and Down arrows are shown for approximately seven seconds. Pressing on the screen time (where the Hold Temperature Until time is shown) allows the arrows to reappear.

- Press Up or Down arrow next to the Time key to set desired time for the thermostat to resume schedule.

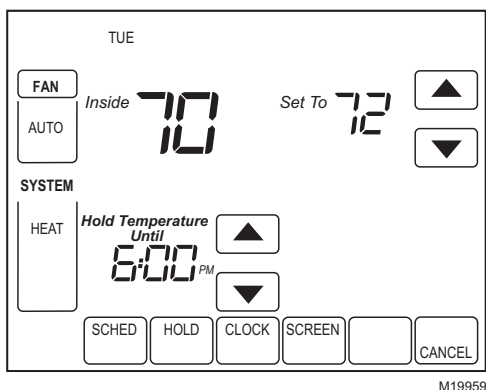

- Press the Cancel or Sched key to cancel "Hold Temperature Until" and resume schedule.

NOTE: Once "Hold Temperature Until" time is reached, the thermostat shows "Following Schedule" on the screen to indicate that "Temporary Hold" has ended.

PERMANENT HOLD

Permanent Hold changes the temperature setting until Permanent Hold is cancelled.

- Press Hold key. "Permanent Hold" appears on the screen.
- Press Up or Down arrow next to the temperature you want to set during "Hold."

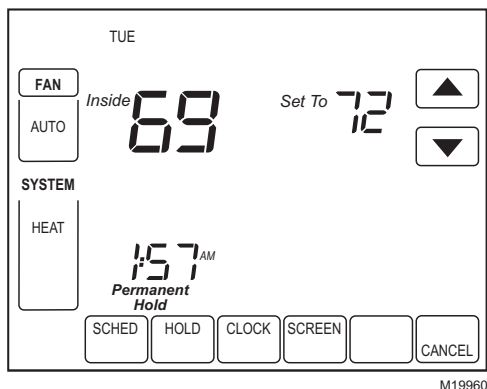

- Press Cancel key to cancel "Permanent Hold" and resume the schedule.

VACATION HOLD

Changes temperature setting for a designated number of days.

- Press the Up and Down arrow keys to set the desired temperature while away on vacation. Notice that "Hold Temperature Until" time is shown on the screen. (This is the time the Vacation Hold override expires after the number of days ends.)
- Press Hold key twice. Screen shows "Hold Temperature Until" one day.

- Press Up and Down arrow keys to change the number of Days you desire thermostat to override the schedule.

NOTE: Days Up and Down arrows appear for approximately seven seconds. Pressing just below Hold Temperature Until on the screen allows the Days Up and Down arrows to reappear.

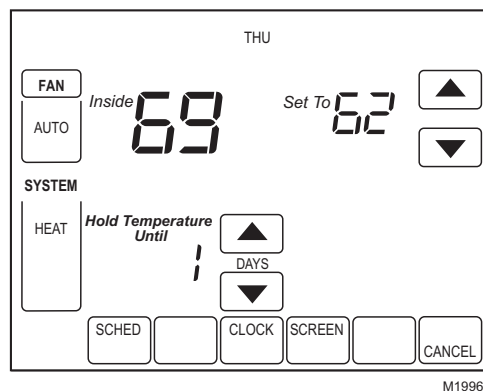

- To cancel the Vacation Hold override early, press the Cancel key.

NOTE: When the number of days of Vacation Hold expires, the screen shows "Following Schedule" to indicate that Vacation Hold has ended.

Clean Thermostat Screen

The thermostat has a touch screen interaction. Follow these steps to clean the screen without making thermostat changes:

- Press the Screen key. Thermostat locks out all touch keys for 30 seconds to allow for cleaning.

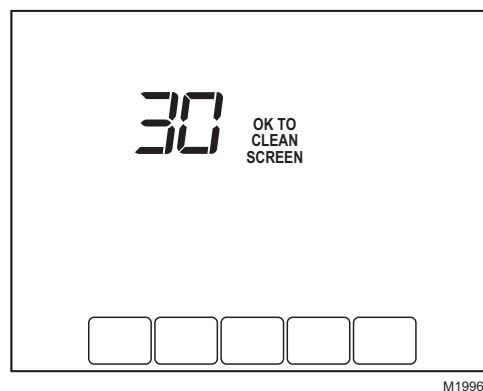

- Use damp cloth slightly moistened with water or household glass cleaner to clean the screen.
- Repeat the above steps, as necessary.

IMPORTANT

Do not spray any type of liquid directly on the thermostat itself. If using household glass cleaner, spray cleaner on cloth. Then use a cloth to clean the thermostat screen.

- Press the Done key to return to the Home Screen and normal operation.

Replace Batteries

1. When the LO Battery indicator is flashing, replace the batteries promptly with three fresh AAA alkaline batteries

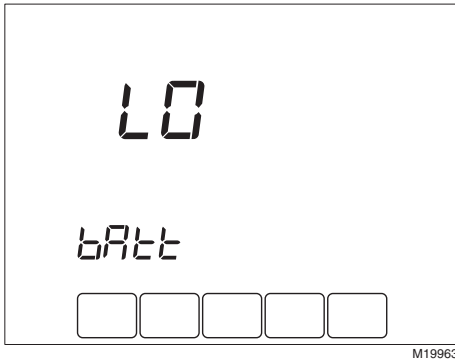

2. Remove thermostat from the wallplate by pulling straight out.

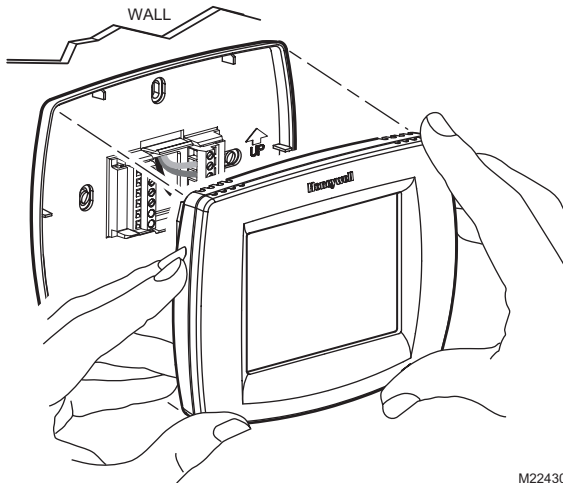

3. Remove the old batteries and insert three fresh AAA alkaline batteries, as marked on the thermostat.

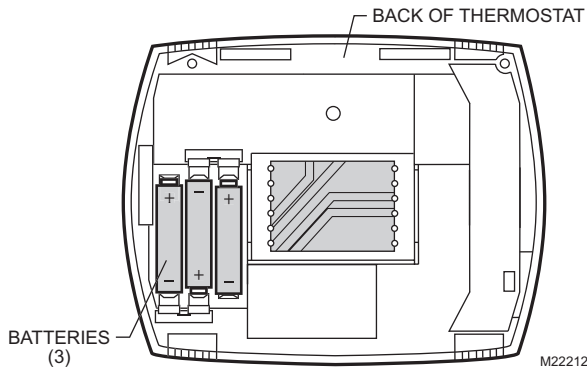

4. Align the screw blocks with the pins on the back of the thermostat.

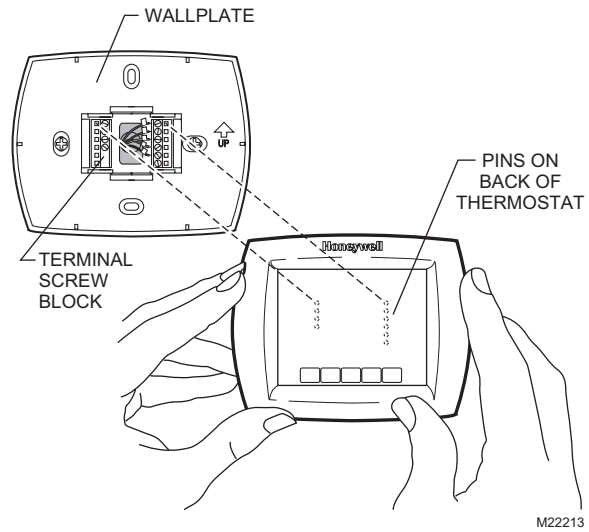

5. Push the thermostat straight onto the wallplate until it snaps into place.

Battery Tips

1. Replace the batteries as soon as LO Batt flashes in the display. The LO Battery indicator flashes in the display one month before the batteries run down completely.
2. Always use fresh AAA alkaline batteries. Non-alkaline batteries do not last as long and can leak, causing thermostat damage.
3. Although the thermostat has a Low Battery indicator, replace the batteries once a year to prevent the thermostat and heating/cooling system from shutting down due to lack of battery power.

Screen Locks

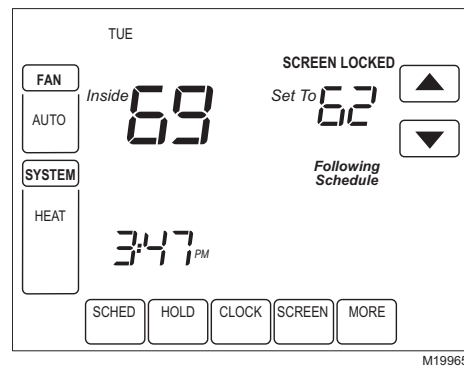

Partially Locked Screen

When partially locked, the screen indicates Screen Locked for 5 to 7 seconds whenever the user attempts to press a key that is locked. Pressing a locked key, while Screen Locked is shown, flashes “Screen Locked” on the screen.

In this mode, all keys are locked except the Temperature Up and Down arrow keys:

- User can change temperature up or down but cannot change schedule settings.
- Temporary temperature change lasts until next scheduled period and that time shows on screen.
- To cancel temperature override and begin following schedule, press Cancel key.
- To unlock screen, see Installer Setup section.

Fully Locked Screen

In this mode, all keys are locked and not functional. To unlock screen, see Installer Setup section. The screen continuously displays “Screen Locked.”

Outdoor Temperature

If an outdoor temperature sensor is installed, the thermostat displays the outside temperature in the lower right corner of the Home Screen.

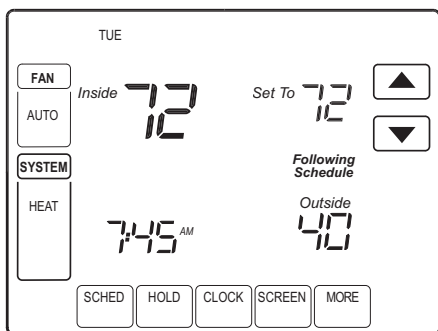

M22453

If thermostat is set to Auto Changeover System mode, press the More key until the outside temperature is shown on the screen.

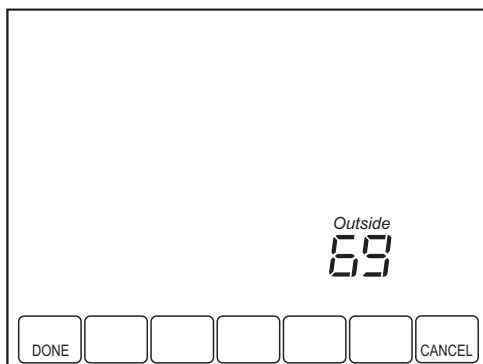

M22448

Remote Indoor Temperature

If a remote indoor temperature sensor is installed, the thermostat displays the inside temperature on the screen from the remote sensor(s). The thermostat internal temperature sensor is not used.

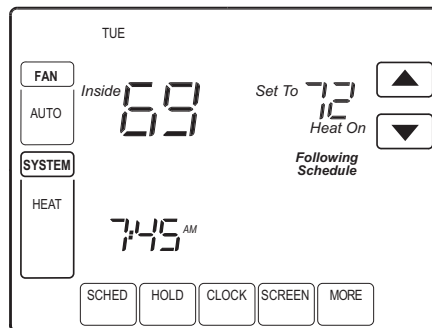

M19974

ONE REMOTE INDOOR SENSOR INSTALLED (OPTIONAL)

If one remote indoor temperature sensor is used, the screen showing the *Inside* temperature reading shows the temperature at the indoor remote sensor location. The thermostat internal temperature sensor is not used.

MULTIPLE REMOTE INDOOR SENSORS INSTALLED (OPTIONAL)

If more than one remote indoor sensor is used, the screen showing *Inside* temperature reading shows the average of all the remote indoor sensors. The thermostat internal temperature sensor is not used.

Indoor Air Quality Reminders

Filter Change Reminder

The filter change reminder must be turned on from the Installer Setup. Once expired, the screen flashes, “Change Filter” and a Reset key appears. Press the Reset key to reset the change reminder.

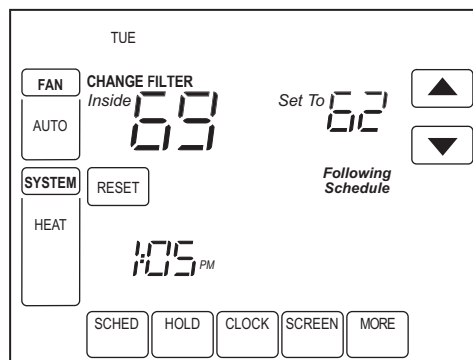

M19975

NOTE: The days are counted as fan run time, so anytime the fan is running, the reminder is counting that time against the number of days selected.

The remaining run time days can be viewed by pressing the More key; the remaining days can be edited using the More key or from the Installer Setup. To view or reset the reminder before it expires, follow these steps using the More key:

1. Press the More key until the filter reminder appears on the screen. This is the number of fan run-time days remaining on the filter reminder.

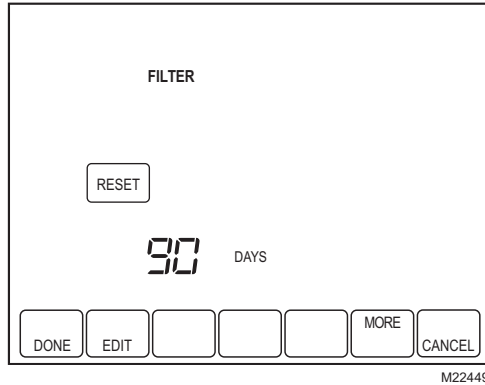

2. Press the Edit key.
3. Use the Up and Down keys to change the number of run-time days.

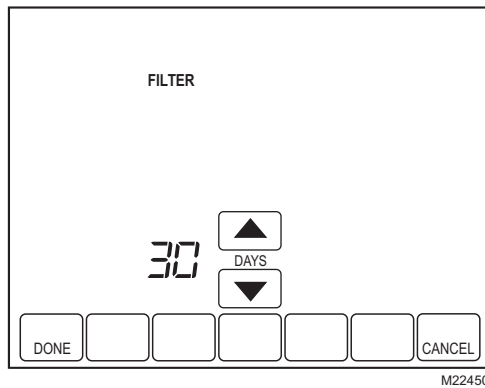

4. Press the Done key to go back to the viewing screen.

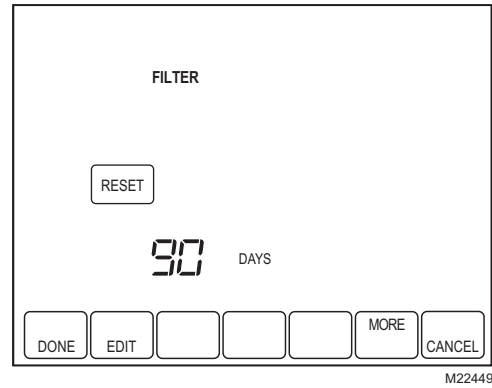

5. Press the Reset key to activate the new number of days selected in the previous screen.

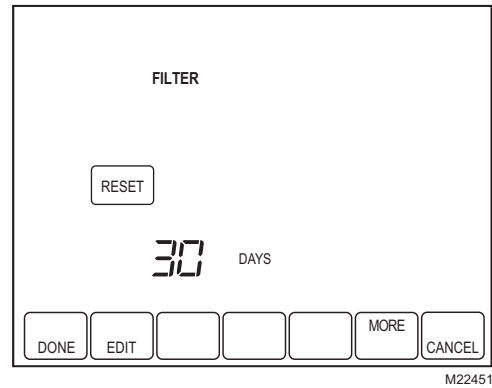

6. Press the Done key to return to the Home screen.

Humidifier Pad Reminder

The Humidifier Pad change reminder must be turned on from the Installer Setup. Once expired, the screen flashes, “Change Humidifier Pad” and a Reset key appears. Press the Reset key to reset the change reminder.

The remaining calendar days can be viewed by pressing the More key. The remaining days can be edited using the More key or from the Installer Setup. To view or reset the reminder before it expires, follow these steps using the More key:

1. Press the More key until the Humidifier Pad change reminder appears on the screen. This is the number of calendar days remaining on the Humidifier Pad reminder.
2. Press the Edit key.
3. Use the Up and Down keys to change the number of calendar days.
4. Press the Done key to go back to the viewing screen.
5. Press the Reset key to activate the new number of days selected in the previous screen.
6. Press the Done key to return to the Home Screen.

UV Lamp Reminder

The UV Lamp change reminder must be turned on from the Installer Setup. Once expired, the screen flashes, “Change UV Lamp” and a Reset key appears. Press the Reset key to reset the change reminder.

The remaining calendar days can be viewed by pressing the More key. The remaining days can be edited using the More key or from the Installer Setup. To view or reset the reminder before it expires, follow these steps using the More key:

1. Press the More key until the UV Lamp change reminder appears on the screen. This is the number of calendar days remaining on the UV Lamp reminder.
2. Press the Edit key.
3. Use the Up and Down keys to change the number of calendar days.
4. Press the Done key to go back to the viewing screen.
5. Press the Reset key to activate the new number of days selected in the previous screen.
6. Press the Done key to return to the Home Screen.

Temperature Recovery

The thermostat feature, Adaptive Intelligent Recovery™, eliminates all guesswork when setting the thermostat schedule.

Simply set the program schedule to the time that the comfort temperature is desired. The thermostat then turns on the heating or cooling at just the right time to have the home reach the scheduled temperature at the scheduled time.

For example—get up at 6:00 AM and want the temperature to be 70°F. Set the Wake period for 6:00 AM and 70°F. The thermostat then turns on the heat before 6:00 AM to raise the temperature to 70°F by 6:00 AM.

The thermostat alerts that the heating or cooling system is coming on before a scheduled time by showing “Recovery” on the screen.

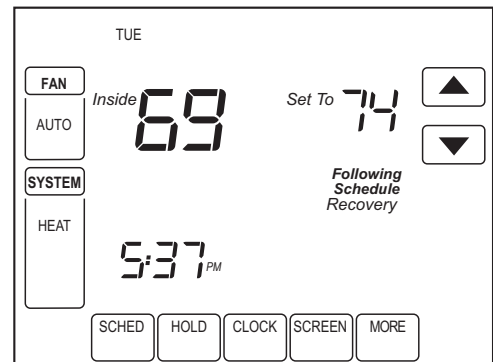

NOTE: It takes about a week for the thermostat to adjust to local weather, the schedule, the construction of the home and the heating and/or cooling system. Each day it adjusts the next day's recovery start time accordingly.

P+I Control

The thermostat microprocessor-based control requires that the user understands temperature control and thermostat performance. A conventional mechanical or electronic thermostat does not control temperature precisely at setpoint. Typically there is an offset (droop) in the control point as the system load changes. This is a phenomenon that most people in the industry know and accept. Many factors contribute to offset including switch differential, thermal lag, overshoot, cycle rates and system load.

The thermostat microprocessor simultaneously gathers, compares and computes data. Using this data, it controls a wide variety of functions. The special proprietary algorithm (program) in the thermostat eliminates the factors causing offset. This makes temperature control more accurate than the conventional mechanical or electronic thermostats. The temperature control algorithm is called proportional plus integral (P+I) control.

The thermostat sensor, located on the thermostat or remote, senses the current space temperature. The proportional error is calculated by comparing the sensed temperature to the programmed setpoint. The deviation from the setpoint is the proportional error.

The thermostat also determines integral error, which is a deviation based on the length of error time. The sum of the two errors is the (P+I) error. The cycle rate used to reach and maintain the setpoint temperature is computed using the P+I. The addition of the integral error is what differentiates the thermostat from many other electronic and mechanical thermostats. See Fig. 31.

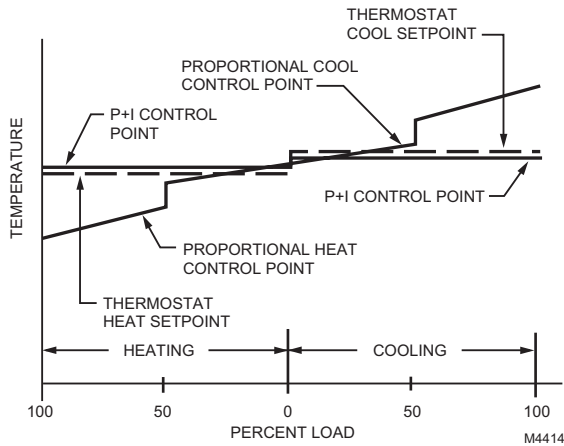

Fig. 31. Proportional temperature control versus P+ I temperature control.

Minimum Off-Timer

The Thermostat has built-in compressor protection (minimum-off timer) that prevents the compressor from restarting too early after a shutdown.

The minimum-off timer is activated after the compressor turns off.

If there is a call during the minimum-off timer, the thermostat shows “Wait” in the display.

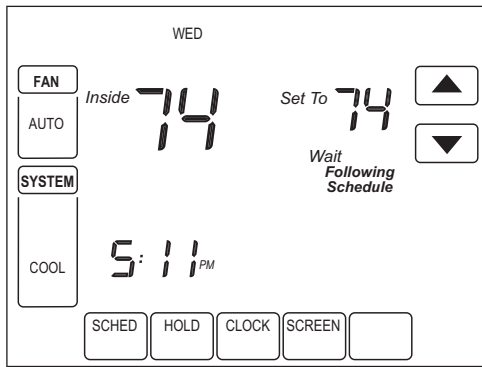

M22244

When the minimum-off timer expires, “Cool On” or “Heat On”^a appears solidly in the display and the compressor and fan turn on.

^aHeat Pumps only.

Inside Humidity Level

Select models can sense the humidity level in the home. The humidity level in the home is shown in the lower right corner of the Home Screen.

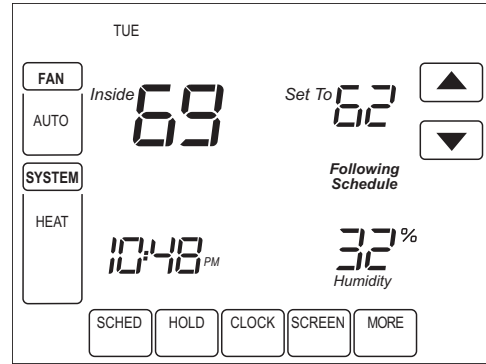

M19966

If thermostat is set to Auto Changeover System mode, press the More key until the humidity level is shown on the screen.

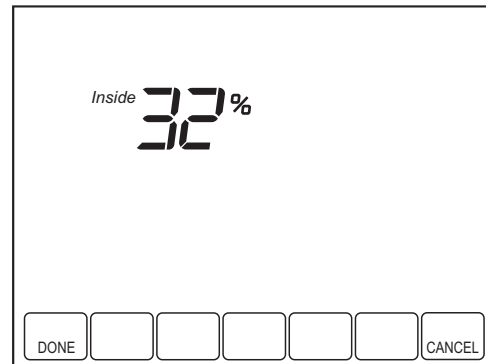

M22452

Control Dehumidification Setting (Select Models)

Select models read the inside humidity level and allow for a dehumidification setting:

1. Press the More key until the inside humidity percent and dehumidification setpoint are shown.

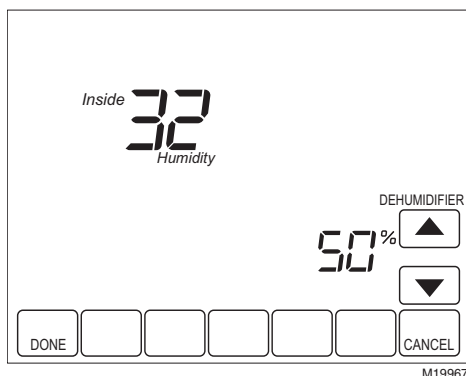

2. Use Up and Down arrow keys, located to the right of the dehumidifier setpoint, to set desired humidity level for dehumidification in the summer.
3. Press Done key.

Dehumidification Droop Control

The dehumidification control attempts to control to the user's humidity setpoint by turning on the air conditioner. In extremely high humidity conditions, the thermostat keeps the air conditioner running (energizing Y and G) for up to 3°F below the temperature setpoint. It does this while trying to achieve the desired humidity setpoint and balancing that with the temperature setpoint. The thermostat controls up to 3° F below the temperature setting until either the humidity is satisfied or conditions change.

Special Heat Pump Operation

Heat Pump LED Indication (Requires 24 Vac Common Connection)

A red LED indication is located in the upper right corner of the thermostat. It is only visible when lighted.

When the L terminal is wired to an equipment monitor, the LED signals when a check or fail signal is sent to the thermostat from the system. This is operational in the Heat, Off, Cool or Auto positions. See Fig. 32.

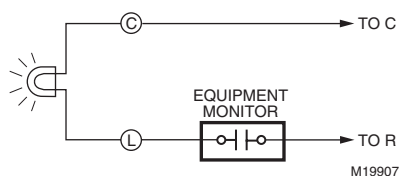

Fig. 32. L terminal switch to R (power) side of system transformer.

Heat Pump Emergency Heat LED Indication (Requires 24 Vac Common Connection)

The thermostat uses a red LED indicator that lights when the thermostat is in the Emergency Heat mode. The LED is located in the upper right corner of the thermostat. It is visible only when on. When the thermostat is in the Em. Heat system mode, the L terminal is continuously energized and the LED is on.

Heat Pump Temperature Lockouts

Dual Fuel Heat Pump and Outdoor Temperature Sensor

In this operation, there is no external fossil fuel kit (dual fuel kit) installed; the thermostat controls this function.

1. Choose correct heat pump application in Installer Setup Number 0170.
2. Choose **Fossil Fuel Option** as the backup heat source in Installer Setup Number 0200.
3. Choose **No External Fossil Fuel Kit Option** is controlling back up heat in Installer Setup Number 0210.
4. Choose **Outdoor Temperature Sensor for Heat Pump Temperature Lockouts Option** in Installer Setup Number 0340.
5. Choose appropriate **Balance Point Temperature** in Installer Setup Number 0350.

OPERATION IN HEAT MODE ABOVE BALANCE POINT (OUTDOOR TEMPERATURE)

When the outdoor temperature is above the selected Balance Point Temperature (ISU 0350), only the compressor operates and the fan (G terminal) energizes when the thermostat calls for heat. See Fig. 33.

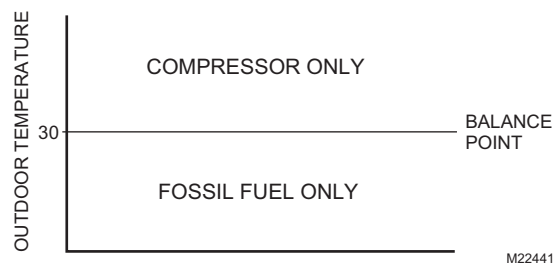

Fig. 33. Dual Fuel Heat Pump Operation in Heat mode with Balance Point Set.

OPERATION IN HEAT MODE BELOW BALANCE POINT (OUTDOOR TEMPERATURE)

When the outdoor temperature is below the selected Balance Point Temperature (ISU 0350), only the Fossil Fuel (auxiliary heat) operates and the fan (G terminal) does not energize when the thermostat calls for heat.

OPERATION IN EMERGENCY HEAT MODE

The balance point (outside) temperature is not used in the Emergency heat mode. When the thermostat is moved to the Emergency Heat position, the compressor is locked out. The first stage of heat is whatever is connected to the E terminal. The second stage of heat is what is connected to the Aux. terminal. Often there is only one source of non-compressor heat and the E terminal is jumped to the Aux. terminal.

Heat Pump with Electric Auxiliary (Backup) Heat and Outdoor Temperature Sensor

1. Choose correct heat pump application in Installer Setup Number 0170.
2. Choose Electric as **Auxiliary (Backup) Heat Source** in Installer Setup Number 0200.
3. Choose **Outdoor Temperature Sensor for Control Option** in Installer Setup Number 0340.
4. Choose **Compressor Lockout Temperature** in Installer Setup Number 0350.
5. Choose **Auxiliary Lockout Temperature** in Installer Setup Number 0360.

NOTE: There is a 5°F deadband between the Compressor and Auxiliary Heat Lockout Temperatures.

Operation in Heat Mode

When the outdoor temperature is below the Compressor Lockout Temperature, only the Auxiliary Heat operates.

When the outdoor temperature is above the Auxiliary Lockout Temperature, only the Compressor operates. See Fig. 34.

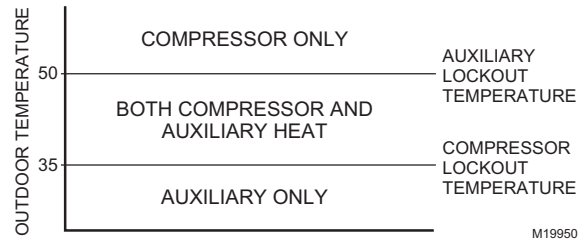

Fig. 34. Heat Pump Operation with Lockout Temperatures Set.

When the outdoor temperature is between the two temperatures, both the Compressor and Auxiliary Heat operate.

Operation in Emergency Heat Mode

Once the thermostat is placed into the Emergency Heat mode, the compressor and auxiliary lockout features are turned off. In the Emergency heat mode, the compressor is locked out. The first stage of heat is whatever is connected to the E terminal. The second stage of heat is connected to the Aux. terminal. Usually the emergency and auxiliary heat sources are electric strip heat in these cases.

Operating Sequence

The thermostat energizes specific terminal(s), depending on the demand for heating, cooling or fan. The thermostat screen shows the time, inside temperature, system and fan selections. Additional indicators are shown when the heating, cooling or fan is energized. See Tables 9 - 11 for specification information.

Table 9. Sequence of Operation for Conventional Systems.

System Setting	Fan Setting	Call for Action	Energize Terminals	Screen Message
Off	Auto	None	None	None
Cool	Auto	None	None	None
Cool or Auto	Auto	Stage 1 Cooling	Y, G	Cool On
Cool or Auto	Auto	Stage 1 and Stage 2 Cooling	Y, Y2 ^b , G	Cool On
Heat	Auto	None	None	None
Heat or Auto	Auto	Stage 1 Heating	W, G ^a	Heat On
Heat or Auto	Auto	Stage 1 and Stage 2 Heating	W, W2 ^c , G ^a	Heat On

^aG energizes only if Installer Setup number 0180 is set to Electric.

^bIf Installer Setup System type is set to two stages of cooling.

^cIf Installer Setup System type is set to two stages of heating.

Table 10. Sequence of Operation for Power Open and Power Closed Valves or Normally Open Valves.

System Setting	Fan Setting	Call for Action	Energize Terminals	Screen message
Off	N/A	None	Y	None
Heat	N/A	None	Y	None
Heat	N/A	Heat	W	Heat On

Table 11. Sequence of Operation for Heat Pump Systems.

System Setting	Fan Setting	Call for Action	Energize Terminals	Screen message
Off	Auto	None	O/B ^a	None
Cool	Auto	None	O/B ^a	None
Cool or Auto	Auto	Stage 1 Cooling	Y, G, O/B ^a	Cool On
Cool or Auto	Auto	Stage 1 and Stage 2 Cooling	Y, Y2 ^d , G, O/B ^a	Cool On
Heat	Auto	None	O/B ^a	None
Heat or Auto	Auto	Stage 1 Heating	Y, G, O/B ^a	Heat On
Heat or Auto	Auto	Stage 1 and Stage 2 Heating	Y, AUX ^c , G, O/B ^a	Aux Heat On
Heat or Auto	Auto	Stage 1, 2 and 3 Heating	Y, Y2 ^d , AUX ^e , G, O/B ^a	Aux Heat On
Em. Heat	Auto	None	L ^b , O/B ^a	None
Em. Heat	Auto	Stage 1 Heating	E, G, L ^b , O/B ^a	Heat On
Em. Heat	Auto	Stage 1 and Stage 2 Heating	E, AUX, G, L ^b , O/B ^a	Aux. Heat On

^aConfigure O/B in Installer Setup. Based on last piece of equipment called (cooling = O or heating = B).

^bRed LED is on. See LED Indication section for more details.

^cIf Installer Setup System Type is set to 2Heat/1Cool Heat Pump with Auxiliary Heat.

^dIf Installer Setup System Type is set to 3Heat/2Cool Heat Pump with Auxiliary Heat.

^eThis terminal does not energize if Installer Setup System type is set to 2 Heat/2 Cool Heat Pump with no Auxiliary Heat.

Second Stage Heat and Cool Control

While maintaining setpoint, several factors affect when 2nd stage energizes such as load conditions, environmental conditions, P+I control, and home insulation. The second stage energizes when the thermostat senses 1st stage is running at 90% capacity. This operation is droopless control.

C7089U Outdoor Temperature Sensor

Operation

When installed with Thermostat Installer Setup Number 0340 set to 1 or 2, the outside temperature can be displayed on the thermostat. See Fig. 35.

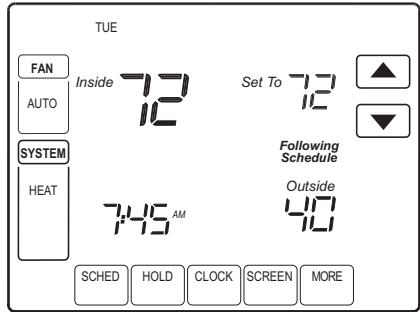

M22453

Fig. 35. Outside temperature reading on TH8000 Series Thermostat.

The C7089 Outdoor Sensor converts outdoor ambient temperature to a resistance that the thermostat can interpret.

The C7089 has a negative temperature coefficient (TC), which means that resistance decreases as the temperature increases. See Table 12.

Checkout

Allow C7089U Outdoor Sensor to absorb outdoor air for a minimum of twenty minutes before taking a reading.

With an accurate thermometer ($\pm 1^{\circ}\text{F}$ [0.5°C]) measure the temperature at the sensor location, allowing time for the thermometer to stabilize before reading.

To verify sensor resistance, remove one wire from one of the C7089 60-in. leadwires. Use an ohmmeter to measure the resistance across the sensor. Then verify the sensor accuracy with the temperature/resistance in Table 12.

Calibration

The C7089 Outdoor Sensor is calibrated at the factory and cannot be recalibrated in the field.

Table 12. Sensor Resistance at Outdoor Temperature.

Outdoor Temperature		Ohms of Resistance	Outdoor Temperature		Ohms of Resistance
°F	°C		°F	°C	
-20	-28.9	106926	52	11.1	17136
-18	-27.8	100923	54	12.2	16387
-16	-26.7	95310	56	13.3	15675
-14	-25.6	90058	58	14.4	14999
-12	-24.4	85124	60	15.6	14356
-10	-23.3	80485	62	16.7	13743
-8	-22.2	76137	64	17.8	13161
-6	-21.1	72060	66	18.9	12607
-4	-20.0	68237	68	20.0	12081
-2	-18.9	64631	70	21.1	11578
0	-17.8	61246	72	22.2	11100
2	-16.7	58066	74	23.3	10644
4	-15.6	55077	76	24.4	10210
6	-14.4	53358	78	25.6	9795
8	-13.3	49598	80	26.7	9398
10	-12.2	47092	82	27.8	9020
12	-11.1	44732	84	28.9	8659
14	-10.0	42506	86	30.0	8315
16	-8.9	40394	88	31.1	7986
18	-7.8	38400	90	32.2	7672
20	-6.7	36519	92	33.3	7372
22	-5.6	34743	94	34.4	7086
24	-4.4	33063	96	35.6	6813
26	-3.3	31475	98	36.7	6551
28	-2.2	29975	100	37.8	6301
30	-1.1	28558	102	38.9	6062
32	0.0	27219	104	40.0	5834
34	1.1	25949	106	41.1	5614
36	2.2	24749	108	42.2	5404
38	3.3	23613	110	43.3	5203
40	4.4	22537	112	44.4	5010
42	5.6	21516	114	45.6	4826
44	6.7	20546	116	46.7	4649
46	7.8	19626	118	47.8	4479
48	8.9	18754	120	48.9	4317
50	10.0	17926	—		

C7189U Remote Indoor Temperature Sensor

Operation

When installed with Thermostat Installer Setup Number 0340 set to 3, the remote inside temperature is displayed on the Thermostat Home Screen as Inside Temperature. The thermostat internal temperature sensor is not used. See Fig. 36.

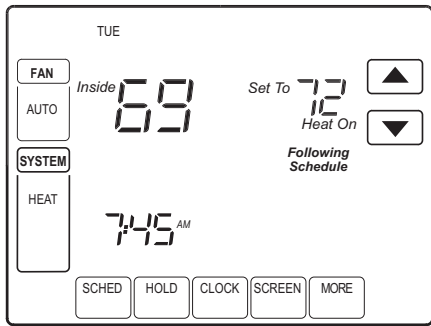

M19974

Fig. 36. Inside temperature reading on TH8000 Series Thermostat.

The C7189 Wall Mount Temperature Sensor converts room temperature to a resistance that the thermostat can interpret.

The C7189 has a negative temperature coefficient (NTC), which means that resistance decreases as the temperature increases. See Table 13.

The C7189 can be used to provide one remote sensor input (see Fig. 28) or as a temperature averaging network with multiple C7189 Sensors connected, as shown in Fig. 29.

Checkout

For best results, allow C7189 Wall Mount Temperature Sensor to absorb the air moving through the room for a minimum of twenty minutes before taking a resistance measurement.

With an accurate thermometer ($\pm 1^\circ\text{F}$ [0.5°C]) measure the temperature at the sensor location, allowing time for the thermometer to stabilize before reading.

To verify sensor resistance, remove one wire from one of C7189 wiring terminals. Use an ohmmeter to measure the resistance across the sensor. Then verify the sensor accuracy with the temperature/resistance in Table 13.

Calibration

The C7189 Wall Mount Temperature Sensor is calibrated at the factory and cannot be recalibrated in the field.

Table 13. Sensor Resistance at Room Temperature.

Room Temperature		Ohms of Resistance	Room Temperature		Ohms of Resistance
°F	°C		°F	°C	
40	4.4	22537	72	22.2	11100
42	5.6	21516	74	23.3	10644
44	6.7	20546	76	24.4	10210
46	7.8	19626	78	25.6	9795
48	8.9	18754	80	26.7	9398
50	10.0	17926	82	27.8	9020
52	11.1	17136	84	28.9	8659
54	12.2	16387	86	30.0	8315
56	13.3	15675	88	31.1	7986
58	14.4	14999	90	32.2	7672
60	15.6	14356	92	33.3	7372
62	16.7	13743	94	34.4	7086
64	17.8	13161	96	35.6	6813
66	18.9	12607	98	36.7	6551
68	20.0	12081	100	37.8	6301
70	21.1	11578	—		

TROUBLESHOOTING (TABLE 14)

Table 14. Troubleshooting.

Symptom	Possible Cause	Action
Display does not come on.	Thermostat is not being powered.	Check for 24 Vac between C and Rc. Check that AAA batteries are installed correctly and are good.
Temperature settings do not change.	The upper or lower temperature limits were reached.	Check temperature setpoints. Check Installer Setup Numbers 0600 and 0610; modify as needed.
	The keypad is fully locked.	Check Installer Setup Number 0670 to change keypad locked options.
Heating or cooling does not come on.	Thermostat minimum off-time is activated.	Wait up to five minutes for the system to respond.
	System selection is not set to Heat or Cool.	Set system Selection to correct position.
	System type Selection is incorrect.	Check Installer Setup Number 0170 and make sure correct System type is chosen.
Thermostat is calling for Heat (Heat on) or Cool (Cool on) but no heating or cooling is running.	Heating or cooling equipment is not operating.	Check wiring. Check Installer Setup Number 0170 and make sure correct system type is chosen. Verify operation of equipment in System Test mode.
Heat does not turn on (Heat On is solid in the display).	Heating equipment failure.	Check for 24 Vac at the equipment on the secondary side of the transformer between power and common. If voltage is not present, check the heating equipment to find the cause of the problem. Check for 24 Vac between the heat terminal (W) and transformer common. If 24 Vac is present, the thermostat is functional. Check the heating equipment to find the cause of the problem.
	Loose or broken wire connection between thermostat and heating equipment.	Check for 24 Vac between the heat terminal (W) and transformer common. If voltage is not present, check wire connection (loose or broken) between the thermostat and the heating equipment.
Cooling does not turn on (Cool On is solid in the display).	Cooling equipment failure.	Check for 24 Vac at the equipment on the secondary side of the transformer between power and common. If voltage is not present, check the cooling equipment to find the cause of the problem. Check for 24 Vac between the cool terminal (Y) and transformer common. If 24 Vac is present, the thermostat is functional. Check the cooling equipment to find the cause of the problem.
	Loose or broken wire connection between thermostat and cooling equipment.	Check for 24 Vac between the cool terminal (Y) and transformer common. If voltage is not present, check the wire connection (loose or broken) between the thermostat and the cooling equipment.
Fan does not turn on in a call for heat (electric furnace).	Fan Control in Heating is set to Gas or Oil Furnace (Setting 0180).	Set Fan Control in Heating to Electric Furnace (Setting 0180).

Table 14. Troubleshooting. (Continued)

Symptom	Possible Cause	Action
Heat pump puts out cool air in the heat mode and warm air in the cool mode.	Changeover Valve (Installer Setup Number 0190) is not configured to match the changeover required by the installed heat pump.	Set Changeover Valve (Installer Setup Number 0190) to match the changeover required by the installed heat pump.
Both the heating and cooling equipment are running at the same time.	The heating equipment is not a heat pump but the System Type (Installer Setup Number 0170) is set to Heat Pump.	Set System Type (Installer Setup Number 0170) to match the installed heating and/or cooling equipment.
	Heating and cooling wires are shorted together.	Separate the shorted heating and cooling wires.
Heating equipment is running in the cool mode.	Heating equipment is not a heat pump but System Type (Installer Setup Number 0170) is set to Heat Pump.	Set System Type (Installer Setup Number 0170) to match the installed heating and/or cooling equipment.
Heating equipment does not turn off and heat temperature setting is set below room temperature (Heat On is not in the display).	Heating equipment is not a heat pump but System Type (Installer Setup Number 0170) is set to Heat Pump.	Set System Type (Installer Setup Number 0170) to match the installed heating and/or cooling equipment.
Cannot set the system setting to Heat.	System Type (Installer Setup Number 0170) is set to Cool Only.	Set System Type (Installer Setup Number 0170) to match the installed heating and/or cooling equipment.
Cannot set the system setting to Cool.	System Type (Installer Setup Number 0170) is set to Heat Only or Heat Only with Fan.	Set System Type (Installer Setup Number 0170) to match the installed heating and/or cooling equipment.
Heat On is not in the display.	System setting is not set to Heat and/or temperature setting is not set above room temperature.	Set the system setting to Heat and set the temperature setting above the room temperature.
Cool On is not in the display.	System setting is not set to Cool and/or the temperature setting is not set below room temperature.	Set the system setting to Cool and set the temperature setting below the room temperature.
Wait is in the display.	Compressor minimum off timer is active.	Wait up to five minutes for the cooling or heating (heat pump) equipment to turn on.
"Screen Locked" appears on the screen and all or some of the keys do not respond.	The keypad is fully or partially locked.	Check Installer Setup Number 0670 to change keypad locked options.

Honeywell

Automation and Control Solutions

Honeywell International Inc.
1985 Douglas Drive North
Golden Valley, MN 55422

Honeywell Limited-Honeywell Limitée
35 Dynamic Drive
Scarborough, Ontario
M1V 4Z9

